

S418
2379
13295

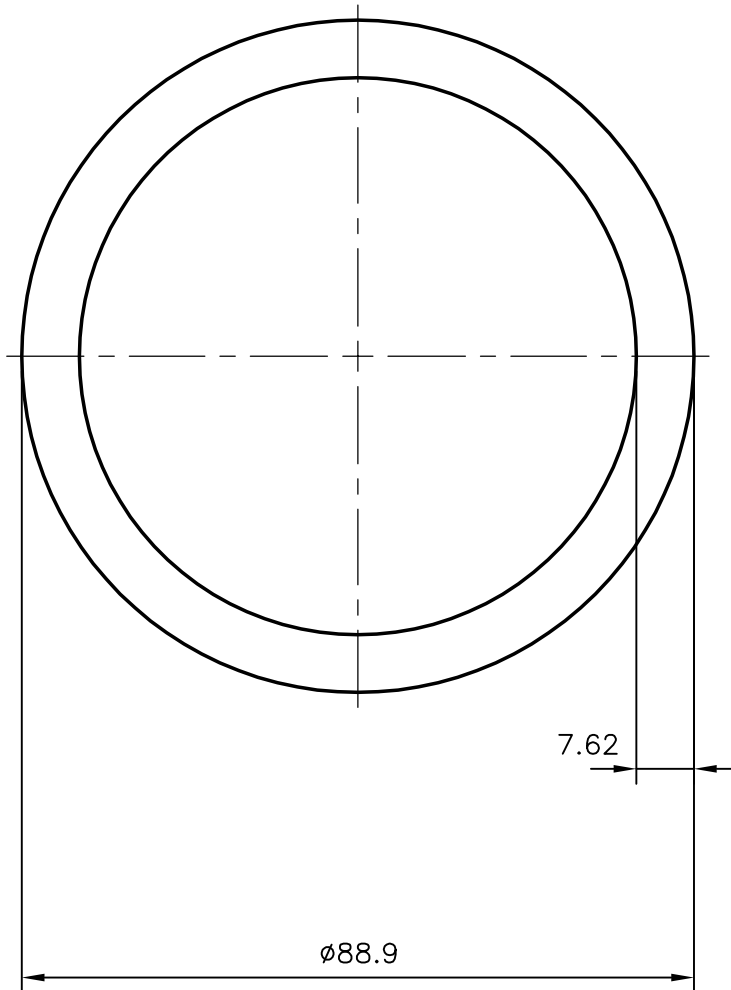

JINDAL ALUMINIUM LTD. <i>BANGALORE-560073</i>			NAME	DATE
		DRAWN	J.P.KAUSHIK	22.10.2005
1. ALL DIMENSIONS ARE IN mm. 2. ROUND OFF ALL SHARP CORNERS WITH 0.4 mm. 3. TOLERANCES WILL BE AS PER IS: 2673-191979, UNLESS OTHERWISE SPECIFIED		CHECKED		
		APPROVED		
		SCALE		4:1
PARTY'S NAME	TATA PROJECTS LIMITED., HYDERABAD.	WEIGHT kg/m		5.253
PARTY'S DRAWING No.	AS PER SPECIFICATION	SECTION No.		13295
ALLOY & TEMPER	E91E WP	DRAWING No.		
LENGTH	6000 mm	13295		
DESCRIPTION	ROUND TUBE			