

2380
13296

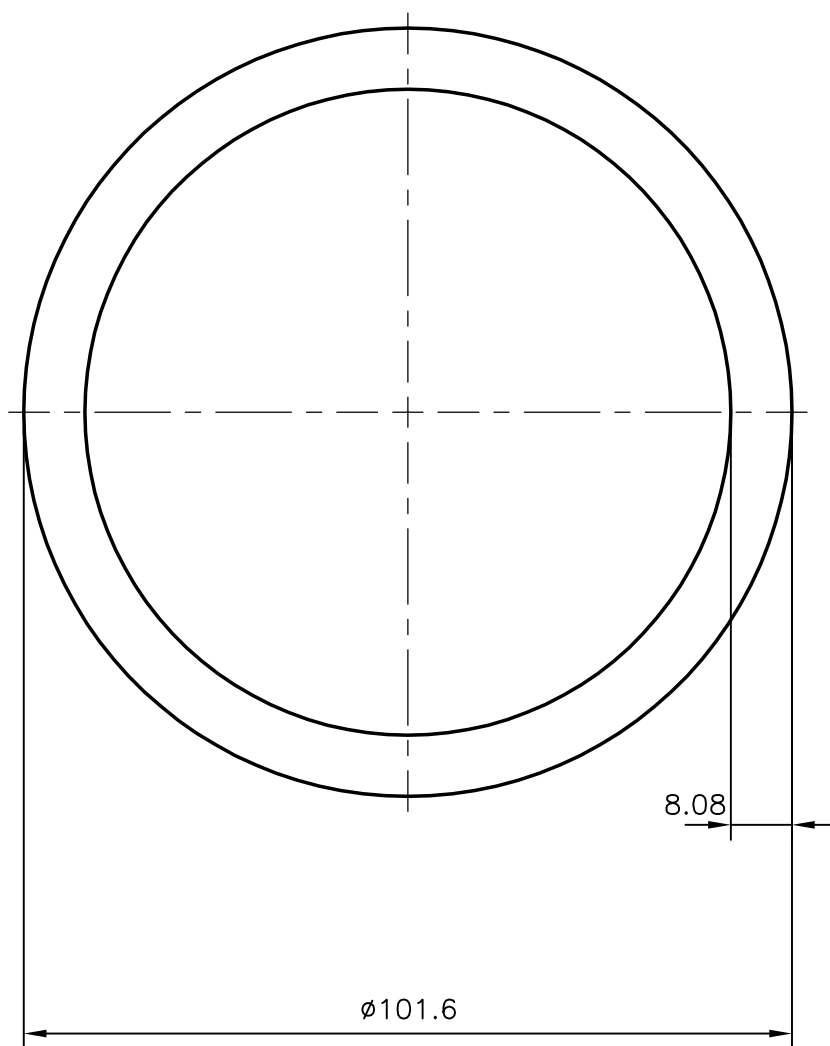

JINDAL ALUMINIUM LTD. BANGALORE-560073			NAME	DATE
		DRAWN	J.P.KAUSHIK	22.10.2005
1. ALL DIMENSIONS ARE IN mm. 2. ROUND OFF ALL SHARP CORNERS WITH 0.4 mm. 3. TOLERANCES WILL BE AS PER BS:1474-1987 ,UNLESS OTHERWISE SPECIFIED		CHECKED		
		APPROVED		
		SCALE	4:1	
PARTY'S NAME	TATA PROJECTS LIMITED., HYDERABAD.	WEIGHT kg/m	6.409	
PARTY'S DRAWING No.	AS PER SPECIFICATION	SECTION No.	13296	
ALLOY & TEMPER	E91E WP	DRAWING No.	13296	
LENGTH	5000 mm			
DESCRIPTION	ROUND TUBE			