

S364

9802

13299

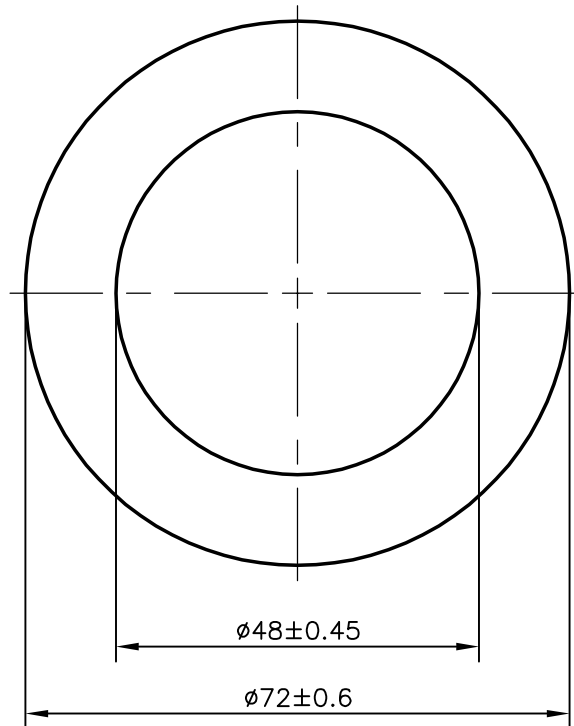

NOTE:- MAXIMUM BEND IS 1.0 mm/MTR.



SYMBOL OF QUALITY
AN ISO 9001 COMPANY

JINDAL ALUMINIUM LTD.
BANGALORE-560073 (INDIA)

	NAME	DATE
DRAWN	PRASANN.H	28-12-2006
CHECKED		
APPROVED		
SCALE		1:1
AREA mm ²		2261.947
PERIMETER mm.		226.195
WEIGHT kg/m		6.107
DRAWING No.	SECTION No.	
S364	S364	
9802	9802	
13299	13299	

1. ALL DIMENSIONS ARE IN mm.
2. ROUND OFF ALL SHARP CORNERS WITH 0.4 mm.
3. TOLERANCES WILL BE AS PER IS:2673-1979 UNLESS OTHERWISE SPECIFIED

PARTY'S NAME	BHARAT ELECTRONICS LIMITED., BANGALORE
PARTY'S DRAWING No.	AS PER SPECIFICATION
ALLOY & TEMPER	6061 T4 (HE20 WP)
DESCRIPTION	ROUND TUBE