

P-4119

S968

9834

13331

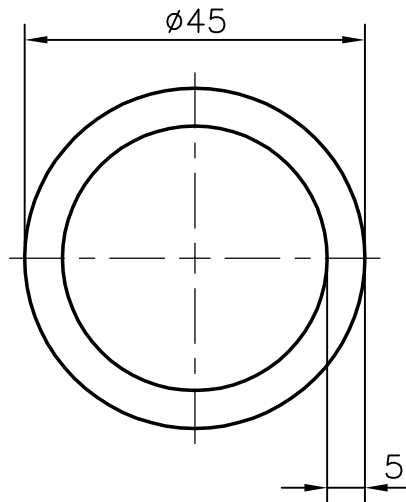

SYMBOL OF QUALITY
AN ISO 9002 COMPANY

JINDAL ALUMINIUM LTD.
BANGALORE-560073 (INDIA)

	NAME	DATE
DRAWN	R.D.Sharma	06-02-03
CHECKED		
APPROVED		
SCALE	1:1	
AREA mm ²	628.3	
PERIMETER mm.	141.4	
WEIGHT kg/m	1.696	
SECTION No.	13331	
DRAWING No.	13331	

1. ALL DIMENSIONS ARE IN mm.
2. ROUND OFF ALL SHARP CORNERS WITH 0.40 mm.
3. TOLERANCES WILL BE AS PER IS: 2673-1979 UNLESS OTHERWISE SPECIFIED

PARTY'S NAME	N.K. JAIN INSTRUMENTS PVT. LTD., AMBALA CANTT
PARTY'S DRAWING No.	AS PER SPECIFICATION
ALLOY & TEMPER	HE9 WP
DESCRIPTION	ROUND TUBE