

PERIMETER = 66.29mm

P-3396-ISSUE 2

S715-ISSUE 2

9839

13336

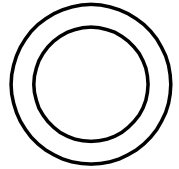

SCALE :1:1

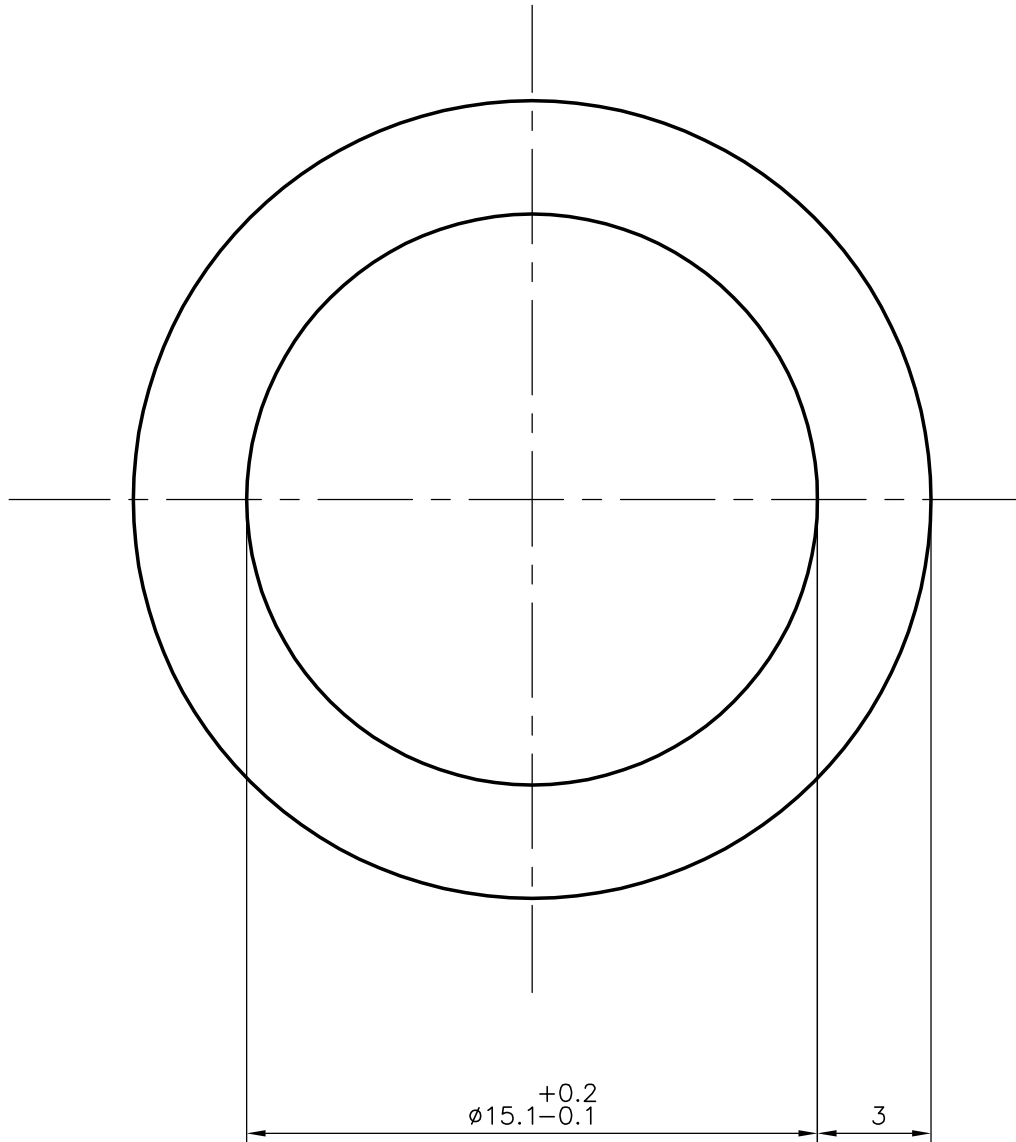

 SYMBOL OF QUALITY AN ISO 9002 COMPANY	JINDAL ALUMINIUM LTD. <i>BANGALORE-560073 (INDIA)</i>		NAME	DATE
		DRAWN	SUDIP ROY	13.07.2001
1. ALL DIMENSIONS ARE IN mm. 2. ROUND OFF ALL SHARP CORNERS WITH 0.40 mm. 3. TOLERANCES WILL BE AS PER IS: 2673-1979 UNLESS OTHERWISE SPECIFIED		CHECKED		
		APPROVED		
PARTY'S NAME	GRIPPERS INC .,MUMBAI	SCALE	5:1 & 1:1	
PARTY'S DRAWING No.	AS PER SPECIFICATION	WEIGHT kg/m	0.460	
ALLOY & TEMPER	E1E "M"	SECTION No.	13336	
DESCRIPTION	ROUND TUBE	DRAWING No.	13336	