

PERIMETER = 75.08mm

P-3397-ISSUE 2

S716-ISSUE 2

9840

13337

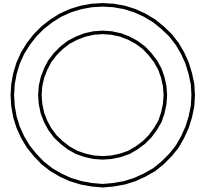

SCALE :1:1

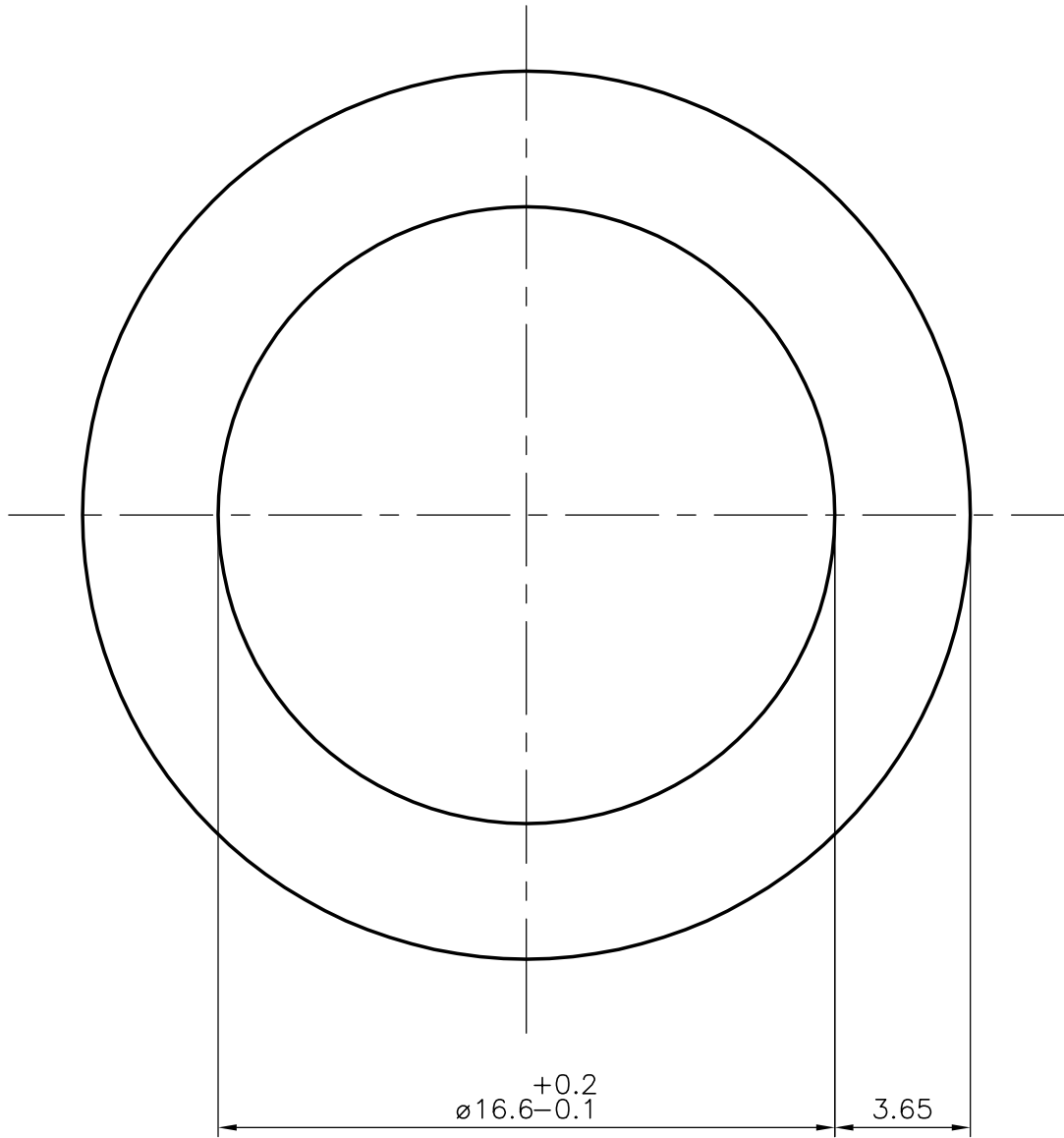

 SYMBOL OF QUALITY AN ISO 9002 COMPANY	<b>JINDAL ALUMINIUM LTD.</b> BANGALORE-560073 (INDIA)		NAME	DATE
		DRAWN	SUDIP ROY	13.07.2001
1. ALL DIMENSIONS ARE IN mm. 2. ROUND OFF ALL SHARP CORNERS WITH 0.40 mm. 3. TOLERANCES WILL BE AS PER IS: 2673-1979 UNLESS OTHERWISE SPECIFIED		CHECKED		
		APPROVED		
PARTY'S NAME	GRIPPERS INC .,MUMBAI	SCALE	5:1 & 1:1	
PARTY'S DRAWING No.	AS PER SPECIFICATION	WEIGHT kg/m	0.626	
ALLOY & TEMPER	E1E "M"	SECTION No.	13337	
DESCRIPTION	ROUND TUBE	DRAWING No.	13337	