

P-4044

S939

13368

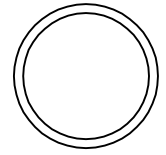

1:1

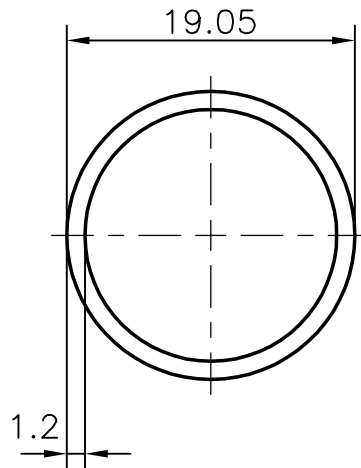

SYMBOL OF QUALITY
AN ISO 9002 COMPANY

JINDAL ALUMINIUM LTD.
BANGALORE-560073 (INDIA)

	NAME	DATE
DRAWN	R.D.Sharma	25-11-02
CHECKED		
APPROVED		

1. ALL DIMENSIONS ARE IN mm.
2. ROUND OFF ALL SHARP CORNERS WITH 0.40 mm.
3. TOLERANCES WILL BE AS PER IS: 2673-1979 UNLESS OTHERWISE SPECIFIED

SCALE	2:1
AREA mm ²	67.3
PERIMETER mm.	59.8

PARTY'S NAME	EMJAY ENTERPRISES, MUMBAI	WEIGHT kg/m	0.182
PARTY'S DRAWING No.	AS PER SPECIFICATION	SECTION No.	13368
ALLOY & TEMPER	HE9 WP	DRAWING No.	13368
DESCRIPTION	ROUND TUBE		