

P-4118

S967

13370

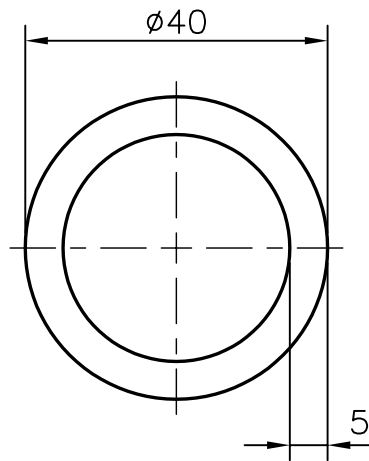

SYMBOL OF QUALITY
AN ISO 9002 COMPANY

JINDAL ALUMINIUM LTD.
BANGALORE-560073 (INDIA)

	NAME	DATE
DRAWN	R.D.Sharma	06-02-03
CHECKED		
APPROVED		

- 1. ALL DIMENSIONS ARE IN mm.
- 2. ROUND OFF ALL SHARP CORNERS WITH 0.40 mm.
- 3. TOLERANCES WILL BE AS PER IS: 2673-1979 UNLESS OTHERWISE SPECIFIED

SCALE	1:1
AREA mm ²	549.8
PERIMETER mm.	125.7
WEIGHT kg/m	1.484
SECTION No.	13370
DRAWING No.	13370

PARTY'S NAME	N.K. JAIN INSTRUMENTS PVT. LTD., AMBALA CANTT
PARTY'S DRAWING No.	AS PER SPECIFICATION
ALLOY & TEMPER	HE9 WP
DESCRIPTION	ROUND TUBE