

P-4983
S1262
13384

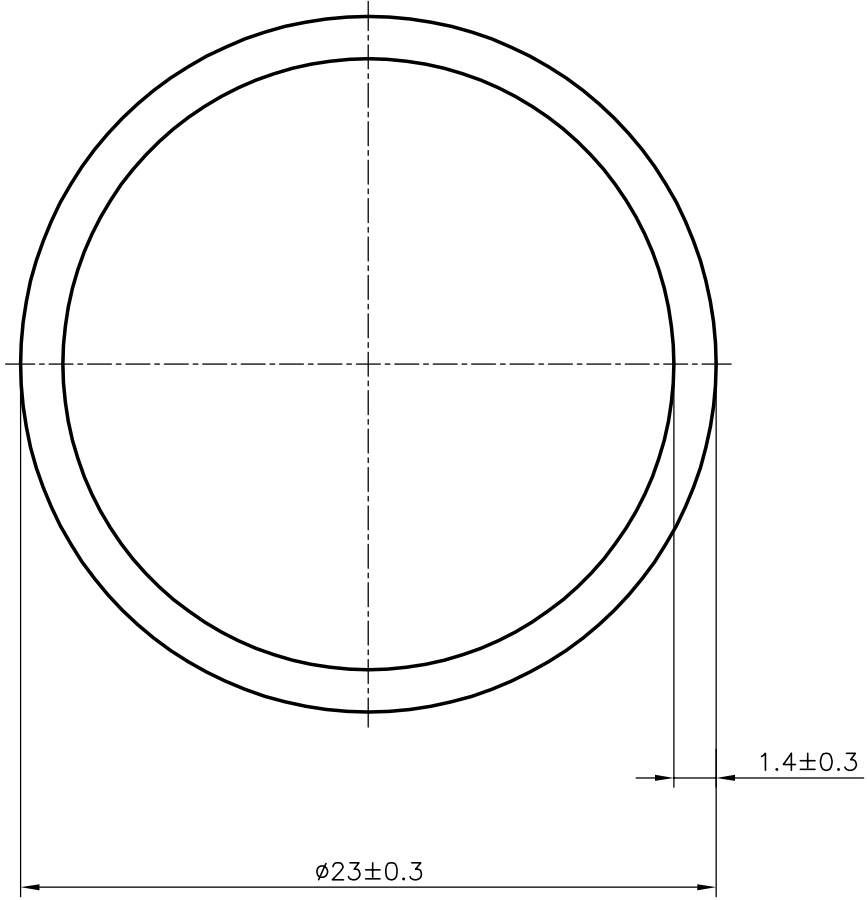
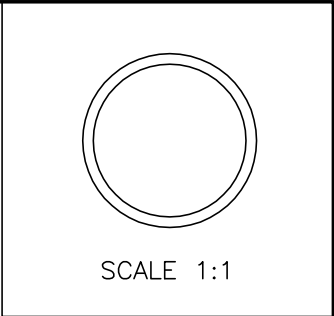

JINDAL ALUMINIUM LTD.
BANGALORE-560073 (INDIA)

	NAME	DATE
DRAWN	RAGHAVENDRA	17-07-2004
CHECKED		
APPROVED		

1. ALL DIMENSIONS ARE IN mm.
2. ROUND OFF ALL SHARP CORNERS WITH 0.40 mm.
3. TOLERANCES WILL BE AS PER IS:2673-2002 UNLESS OTHERWISE SPECIFIED

SCALE	4:1
AREA mm ²	95.002
PERIMETER mm.	72.257
WEIGHT kg/m	0.257

PARTY'S NAME	MAC DECOR LIMITED, NEW DELHI
PARTY'S DRAWING No.	AS PER SPECIFICATION
ALLOY & TEMPER	HE9 WP
DESCRIPTION	ROUND TUBE

DRAWING No.	SECTION No.
P-4983	-
S1262	S1262
13384	13384