

P-5082
S1417
13419

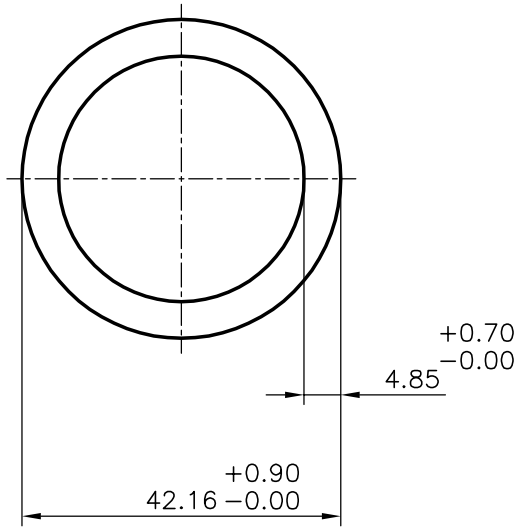

JINDAL ALUMINIUM LTD.
BANGALORE-560073 (INDIA)

	NAME	DATE
DRAWN	RAGHAVENDRA	29-09-2004
CHECKED		
APPROVED		

1. ALL DIMENSIONS ARE IN mm.
2. ROUND OFF ALL SHARP CORNERS WITH 0.40 mm.
3. TOLERANCES WILL BE AS PER IS:2673-2002 UNLESS OTHERWISE SPECIFIED

SCALE	1:1
AREA mm ²	568.482
PERIMETER mm.	132.45
WEIGHT kg/m	1.535

PARTY'S NAME	ALSTOM LIMITED, NEW DELHI
PARTY'S DRAWING No.	AS PER SPECIFICATION
ALLOY & TEMPER	E91E WP
DESCRIPTION	ROUND TUBE

DRAWING No.	SECTION No.
P-5082	P-5082
S1417	S1417
13419	13419