

P-6031-1

S1656

13442

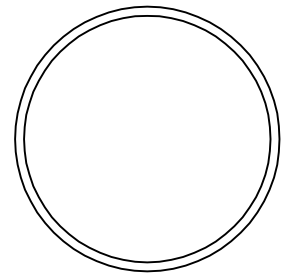

1:1

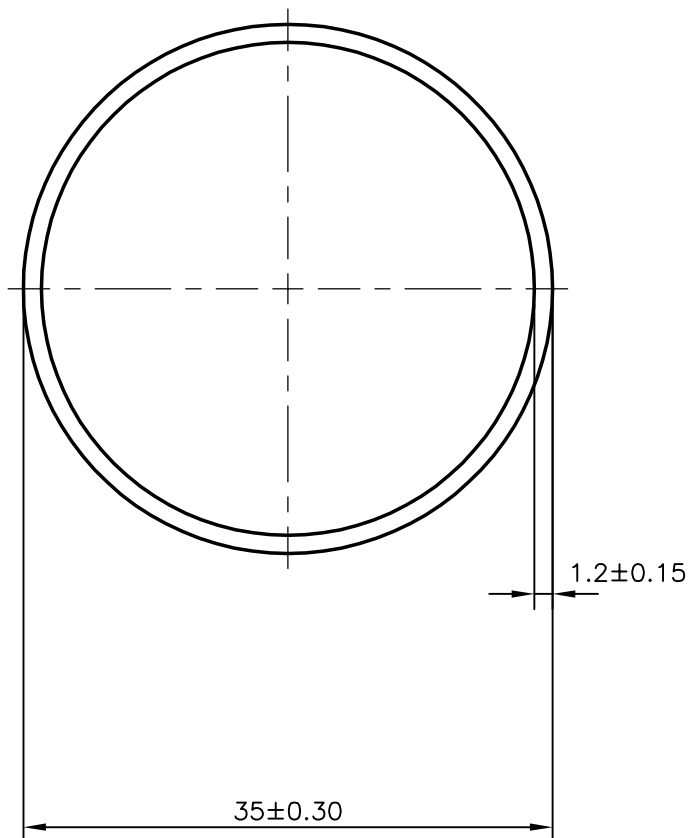

SYMBOL OF QUALITY
AN ISO 9001 COMPANY

JINDAL ALUMINIUM LTD.
BANGALORE-560073 (INDIA)

	NAME	DATE
DRAWN	J.P.KAUSHIK	07-12-2005
CHECKED		
APPROVED		

1. ALL DIMENSIONS ARE IN mm.
2. ROUND OFF ALL SHARP CORNERS WITH 0.40 mm.
3. TOLERANCES WILL BE AS PER IS:2673-2002 UNLESS OTHERWISE SPECIFIED

SCALE	2:1
AREA mm ²	127.423
PERIMETER mm.	109.956
WEIGHT kg/m	0.344

PARTY'S NAME	KARNATAKA ENGG.ENTERPRISES,BANGALORE
PARTY'S DRAWING No.	AS PER SPECIFICATION
ALLOY & TEMPER	HE9 WP
DESCRIPTION	ROUND TUBE

DRAWING No.	SECTION No.
P-6031-1	-
S1656	S1656
13442	13442