

P-6519-1

S1796

13443

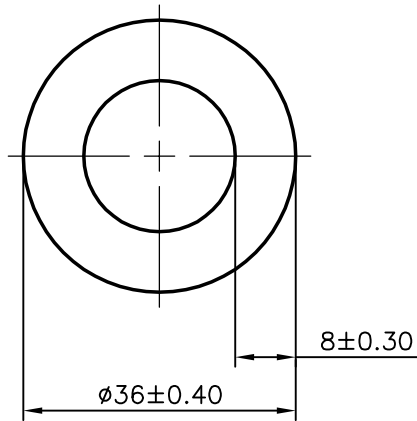

SYMBOL OF QUALITY
AN ISO 9001 COMPANY

JINDAL ALUMINIUM LTD.
BANGALORE-560073 (INDIA)

	NAME	DATE
DRAWN	malingappa	30-06-2006
CHECKED		
APPROVED		
SCALE		1:1
AREA mm ²		703.717
PERIMETER mm.		113.097
WEIGHT kg/m		1.900
DRAWING No.		SECTION No.
P-6519-1		-
S1796		S1796
13443		13443

1. ALL DIMENSIONS ARE IN mm.
2. ROUND OFF ALL SHARP CORNERS WITH 0.40 mm.
3. TOLERANCES WILL BE AS PER IS:2673-2002 UNLESS OTHERWISE SPECIFIED

PARTY'S NAME	SUBROS LIMITED, NOIDA (U.P.)
PARTY'S DRAWING No.	AS PER SPECIFICATION (600007-0480-O-L)
ALLOY & TEMPER	3103 "M"
DESCRIPTION	ROUND TUBE