

P-6156-2

S1703

13454

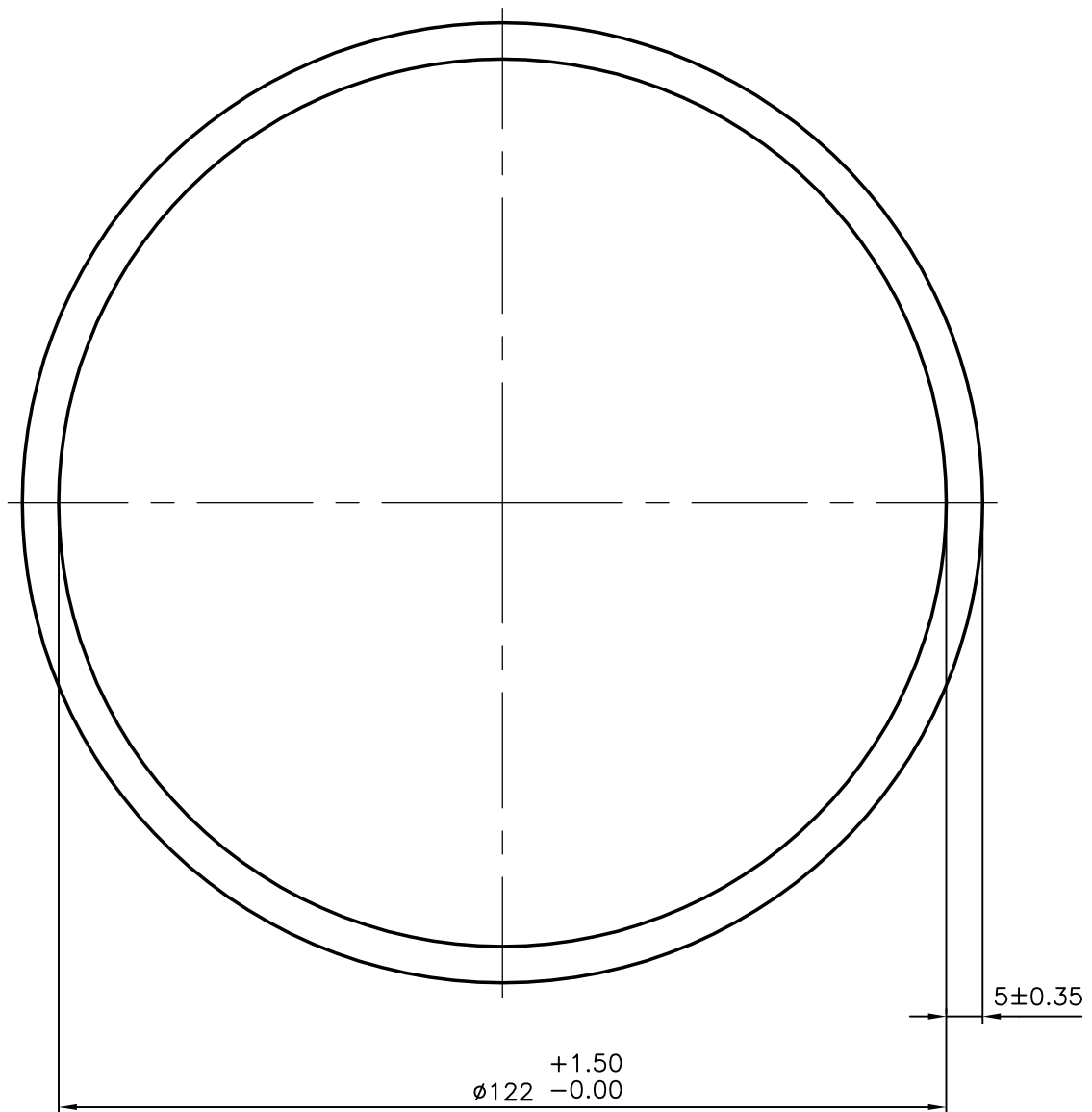

OVALITY = 2mm



SYMBOL OF QUALITY
AN ISO 9001 COMPANY

JINDAL ALUMINIUM LTD.
BANGALORE-560073 (INDIA)

	NAME	DATE
DRAWN	MALINGAPPA	01-02-2006
CHECKED		
APPROVED		
SCALE		1:1
AREA mm ²		1994.911
PERIMETER mm.		414.69
WEIGHT kg/m		5.386
DRAWING No.		SECTION No.
P-6156-2		-
S1703		S1703
13454		13454

1. ALL DIMENSIONS ARE IN mm.
2. ROUND OFF ALL SHARP CORNERS WITH 0.40 mm.
3. TOLERANCES WILL BE AS PER IS:2673-2002 UNLESS OTHERWISE SPECIFIED

PARTY'S NAME	GRIPWEL FASTENERS, NOIDA (U.P.)
PARTY'S DRAWING No.	AS PER SPECIFICATION
ALLOY & TEMPER	6061 T6
DESCRIPTION	ROUND TUBE