

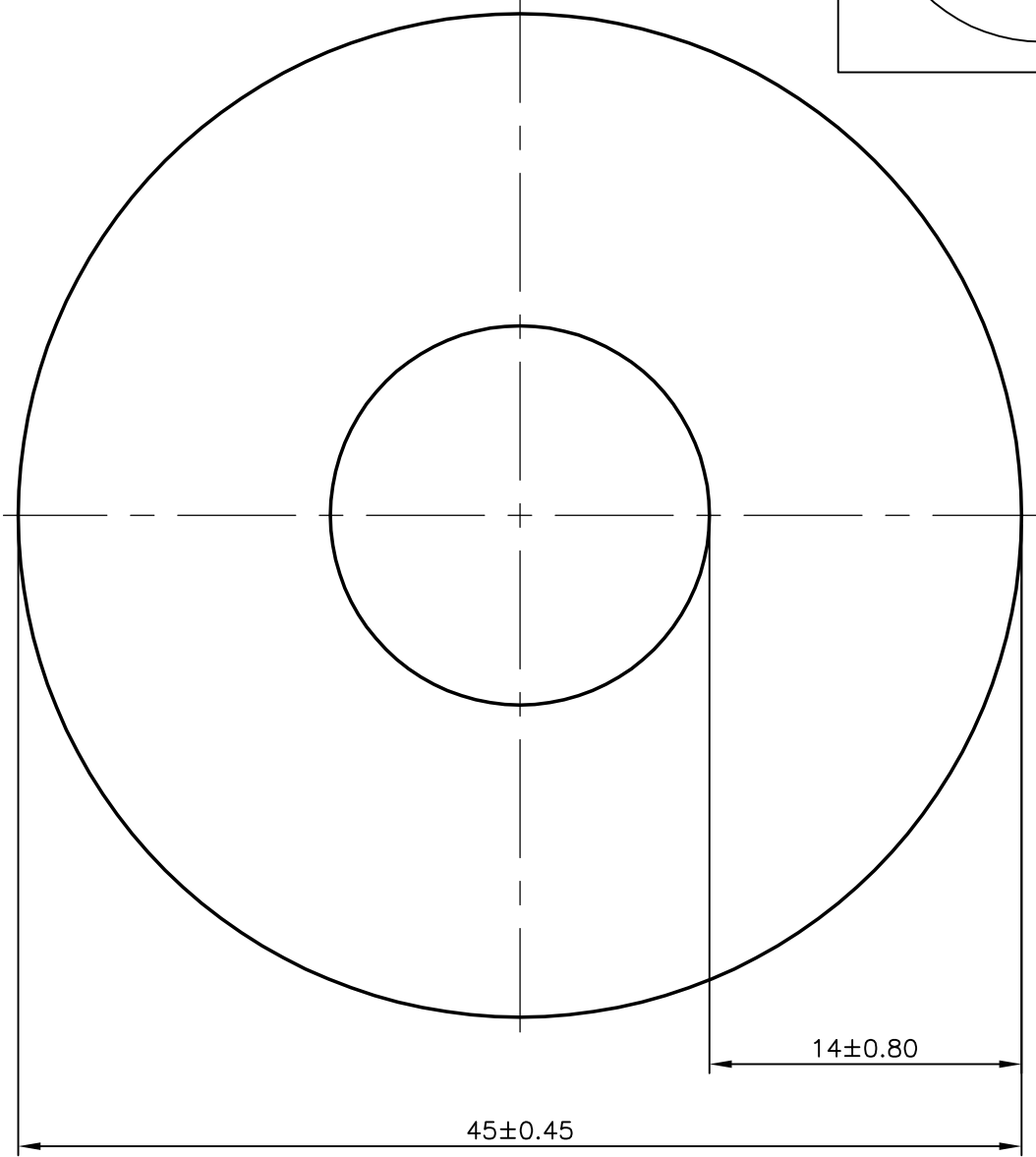

P-7450-1
S2060
13487

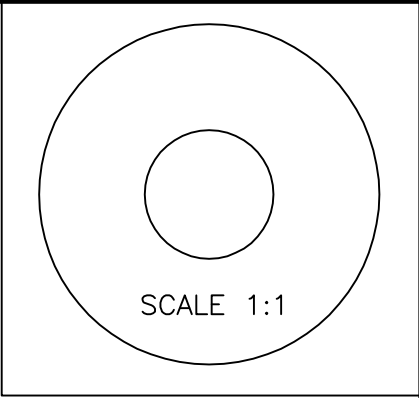

NOTE:-

- PLEASE CONFIRM ALL THE DIMENSIONS AND MATCH WITH YOUR MATCHING COMPONENT

 SYMBOL OF QUALITY AN ISO 9001 COMPANY	JINDAL ALUMINIUM LTD. BANGALORE-560073 (INDIA)	NAME		DATE
		DRAWN	PRASANN.H	11-08-2007
1. ALL DIMENSIONS ARE IN mm. 2. ROUND OFF ALL SHARP CORNERS WITH 0.40 mm. 3. TOLERANCES WILL BE AS PER IS:2673-2002 UNLESS OTHERWISE SPECIFIED		CHECKED		
		APPROVED		
PARTY'S NAME PRISM ENTERPRISES-UNIT1, BELGAUM		SCALE		3:1
		AREA mm ²		1363.451
PARTY'S DRAWING No. AS PER SPECIFICATION		PERIMETER mm.		141.372
		WEIGHT kg/m		3.681
ALLOY & TEMPER 6061 T6		DRAWING No.		SECTION No.
		P-7450-1		-
DESCRIPTION ROUND TUBE		S2060		S2060
		13487		13487