

P-9423-2

S2260

13493

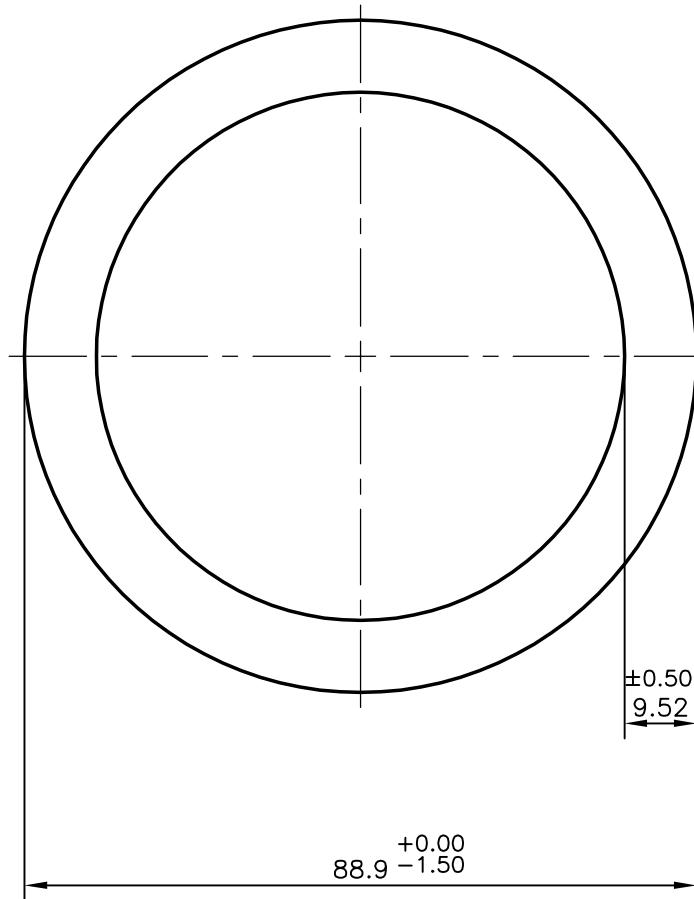

TWIST & BAND TOLERANCE:- 1.5/mtr

OVALITY ± 1% OF DIAMETER



SYMBOL OF QUALITY
AN ISO 9001 COMPANY

JINDAL ALUMINIUM LTD.
BANGALORE-560073 (INDIA)

	NAME	DATE
DRAWN	J.P.KAUSHIK	11-08-2009
CHECKED		
APPROVED		
SCALE		1:1
AREA mm ²		2374.094
PERIMETER mm.		279.288
WEIGHT kg/m		6.41
DRAWING No.		SECTION No.
P-9423-2		-
S2260		S2260
13493		13493

1. ALL DIMENSIONS ARE IN mm.
2. ROUND OFF ALL SHARP CORNERS WITH 0.40 mm.
3. TOLERANCES WILL BE AS PER IS:2673-2002 UNLESS OTHERWISE SPECIFIED

PARTY'S NAME	HIVELM INDUSTRIES, CHENNAI
PARTY'S DRAWING No.	AS PER DRAWING
ALLOY & TEMPER	6101 T6
DESCRIPTION	ROUND TUBE