

P-10867-2

S2886

13515

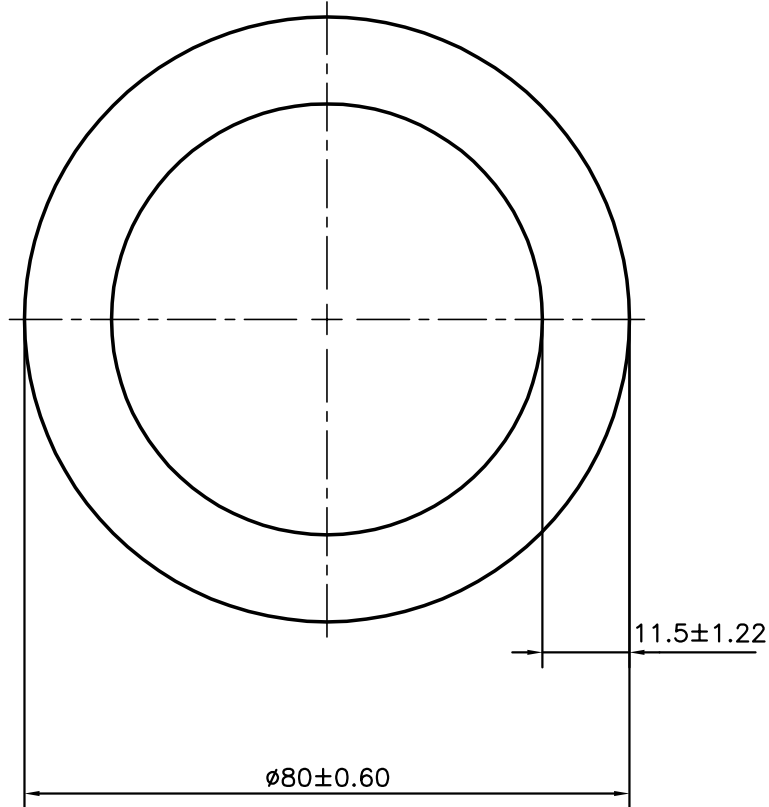

OVALITY = ± 1.30 mm



SYMBOL OF QUALITY
AN ISO 9001 COMPANY

JINDAL ALUMINIUM LTD.
BANGALORE-560073 (INDIA)

| | NAME | DATE |
|----------------------|-------------|------------|
| DRAWN | RAGHAVENDRA | 29-03-2011 |
| CHECKED | | |
| APPROVED | S.S.GARG | 30-03-2011 |
| SCALE | | 1:1 |
| AREA mm ² | | 2474.79 |
| PERIMETER mm. | | 251.327 |
| WEIGHT kg/m | | 6.682 |
| DRAWING No. | SECTION No. | |
| P-10867-2 | - | |
| S2886 | S2886 | |
| 13515 | 13515 | |
| | | |
| | | |

1. ALL DIMENSIONS ARE IN mm.
2. ROUND OFF ALL SHARP CORNERS WITH 0.40 mm.
3. TOLERANCES WILL BE AS PER, IS:2673-2002 UNLESS OTHERWISE SPECIFIED

| | |
|---------------------|---|
| PARTY'S NAME | AREVA T & D INDIA LTD.(ITR DIVISION), HOSUR |
| PARTY'S DRAWING No. | AS PER SPECIFICATION |
| ALLOY & TEMPER | HE30 WP |
| DESCRIPTION | ROUND TUBE |