

P-9458-1

S2282

13517

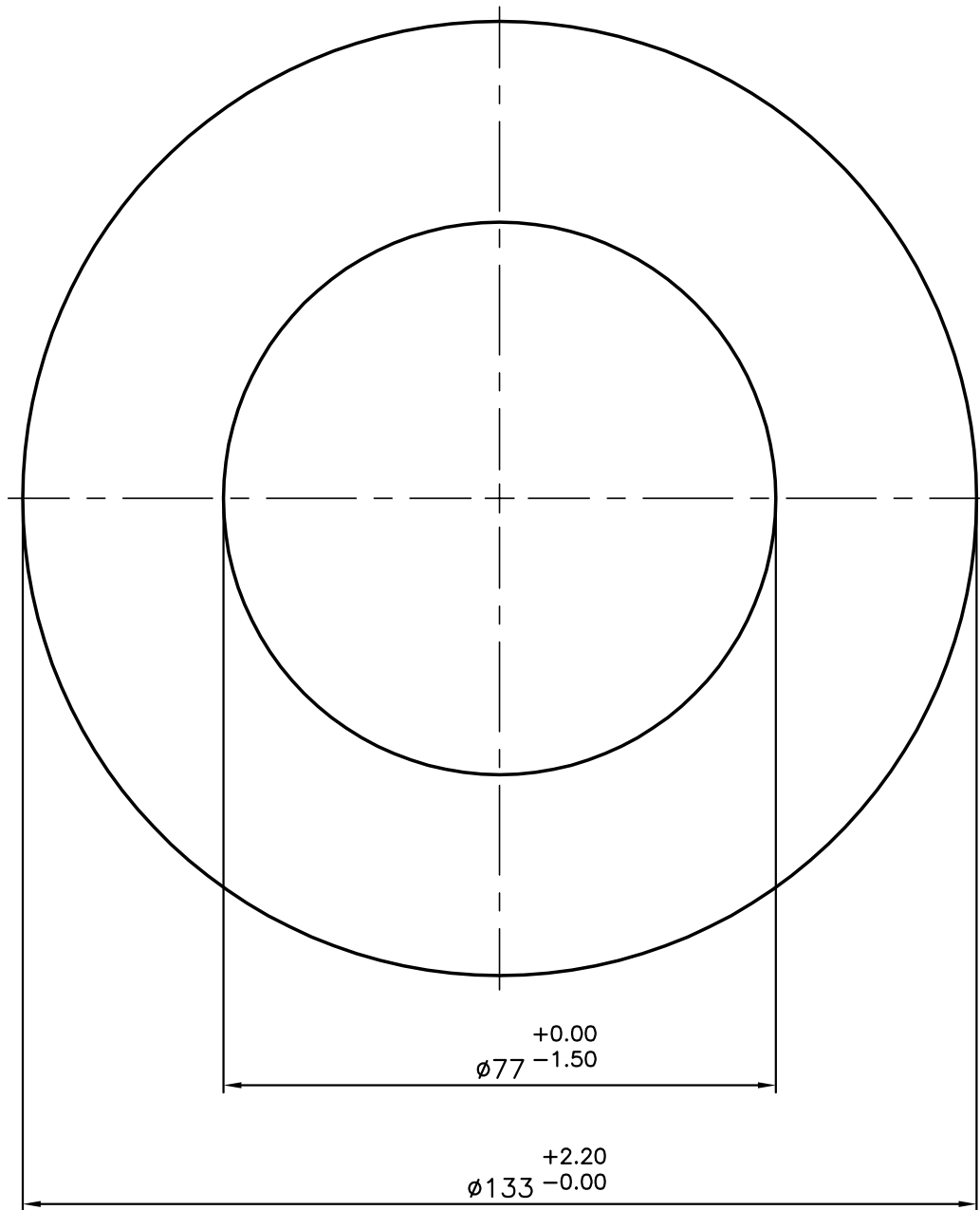

SYMBOL OF QUALITY  
AN ISO 9001 COMPANY

**JINDAL ALUMINIUM LTD.**  
BANGALORE-560073 (INDIA)

	NAME	DATE
DRAWN	J.P.KAUSHIK	05-09-2009
CHECKED		
APPROVED		
SCALE		1:1
AREA mm <sup>2</sup>		9236.282
PERIMETER mm.		417.832
WEIGHT kg/m		24.938
DRAWING No.	SECTION No.	
P-9458-1	-	
S2282	S2282	
13517	13517	

1. ALL DIMENSIONS ARE IN mm.
2. ROUND OFF ALL SHARP CORNERS WITH 0.4mm.
3. TOLERANCES WILL BE AS PER IS:2673-2002 UNLESS OTHERWISE SPECIFIED

PARTY'S NAME	BIESSE MANUFACTURING COMPANY.PVT.LTD., BANGALORE
PARTY'S DRAWING No.	GSK4500001
ALLOY & TEMPER	6060 T5
DESCRIPTION	ROUND TUBE