

P-10633

S2812

13552

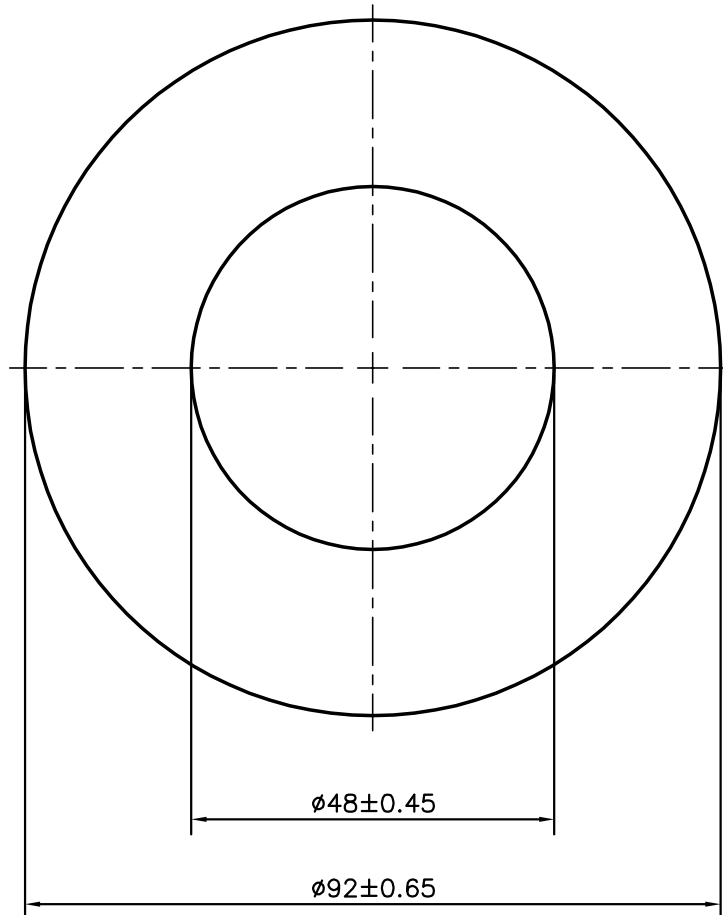

SYMBOL OF QUALITY  
AN ISO 9001 COMPANY

**JINDAL ALUMINIUM LTD.**  
**BANGALORE-560073 (INDIA)**

	NAME	DATE
DRAWN	J.P.KAUSHIK	10-12-2010
CHECKED		
APPROVED	S.S.GARG	25-12-2010
SCALE		1:1
AREA mm <sup>2</sup>		4838.053
PERIMETER mm.		289.027
WEIGHT kg/m		13.063
DRAWING No.	SECTION No.	
P-10633	-	
S2812	S2812	
13552	13552	

1. ALL DIMENSIONS ARE IN mm.
2. ROUND OFF ALL SHARP CORNERS WITH 0.40 mm.
3. TOLERANCES WILL BE AS PER, IS:2673-2002 UNLESS OTHERWISE SPECIFIED

PARTY'S NAME	KIRLOSKAR TOYODA TEXTILE MACHINERY PVT. LTD., BANGALORE
PARTY'S DRAWING No.	AS PER SPECIFICATION
ALLOY & TEMPER	6061 T5
DESCRIPTION	ROUND TUBE