

P-11805

S3359

13553

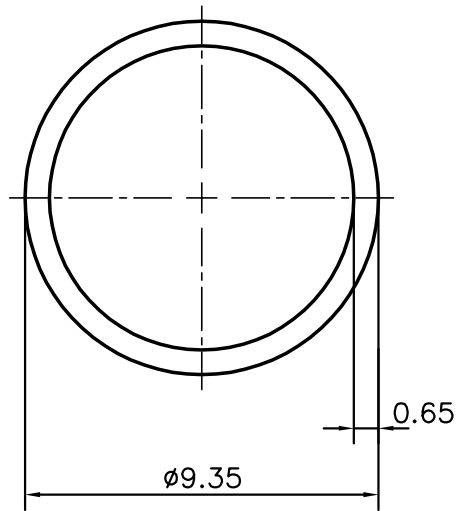

SCALE ; 1:1

**ISSUE-2: -**

THICKNESS REDUCED FROM 0.8mm. TO 0.65mm.
AS PER CUSTOMER REQUIRMENT.



SYMBOL OF QUALITY
AN ISO 9001 COMPANY

JINDAL ALUMINIUM LTD.
BANGALORE-560073 (INDIA)

	NAME	DATE
DRAWN	PARVESH	17-11-2012
CHECKED		
APPROVED	S.S.GARG	22-11-2012
SCALE		5:1
AREA mm ²		17.766
PERIMETER mm.		29.374
WEIGHT kg/m		0.048
DRAWING No.		SECTION No.
P-11805		-
S3359		S3359 (ISSUE-2)
13553		13553

1. ALL DIMENSIONS ARE IN mm.
2. ROUND OFF ALL SHARP CORNERS WITH 0.40 mm.
3. TOLERANCES WILL BE AS PER IS:2673-2002, UNLESS OTHERWISE SPECIFIED

PARTY'S NAME	V.R. INDUSTRIES, NEW DELHI
PARTY'S DRAWING No.	AS PER SPECIFICATION
ALLOY & TEMPER	E1E M
DESCRIPTION	ROUND TUBE