

P-12447

S3664

13577

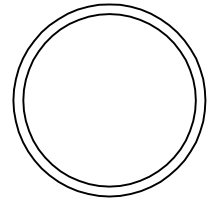

SCALE 1:1

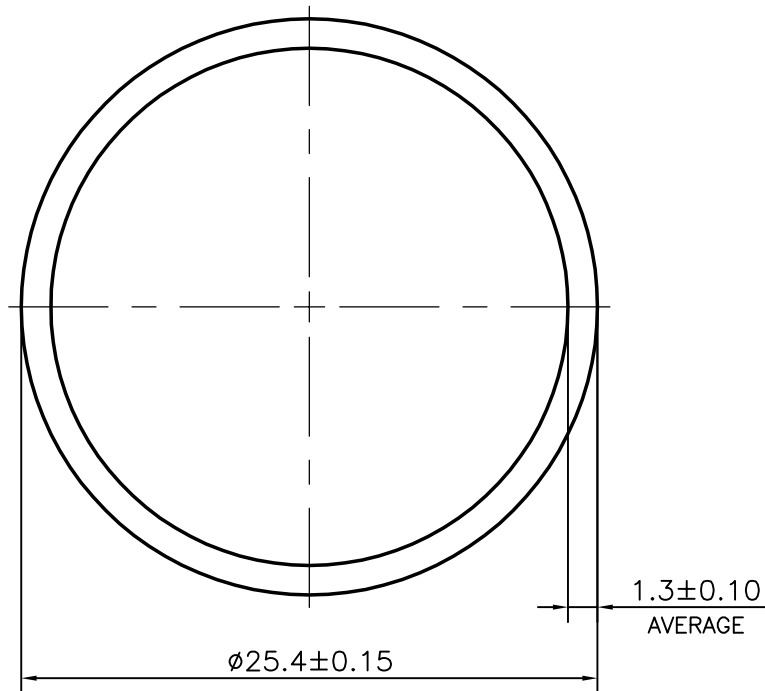

PLEASE NOTE:—

THE ECCENTRIC TOLERANCE WILL BE ± 0.15 mm (MAXIMUM 0.30 mm)

SYMBOL OF QUALITY
AN ISO 9001 COMPANY

JINDAL ALUMINIUM LTD.
BANGALORE-560073 (INDIA)

	NAME	DATE
DRAWN	SRIVATHSA	17-01-2013
CHECKED		
APPROVED	S.S.GARG	20-02-2013
SCALE		3:1
AREA mm ²		98.426
PERIMETER mm.		79.796
WEIGHT kg/m		0.266
DRAWING No.		SECTION No.
P-12447		-
S3664		S3664
13577		13577

1. ALL DIMENSIONS ARE IN mm.
2. ROUND OFF ALL SHARP CORNERS WITH 0.40 mm.
3. TOLERANCES WILL BE AS PER BS:EN:12020-2, UNLESS OTHERWISE SPECIFIED

PARTY'S NAME	MEDIPEDIC SURGICALS, UMBERGAON, VALSAD
PARTY'S DRAWING No.	AS PER SKETCH
ALLOY & TEMPER	6063 T6
DESCRIPTION	ROUND TUBE