

P-11399-1

S3203

13586

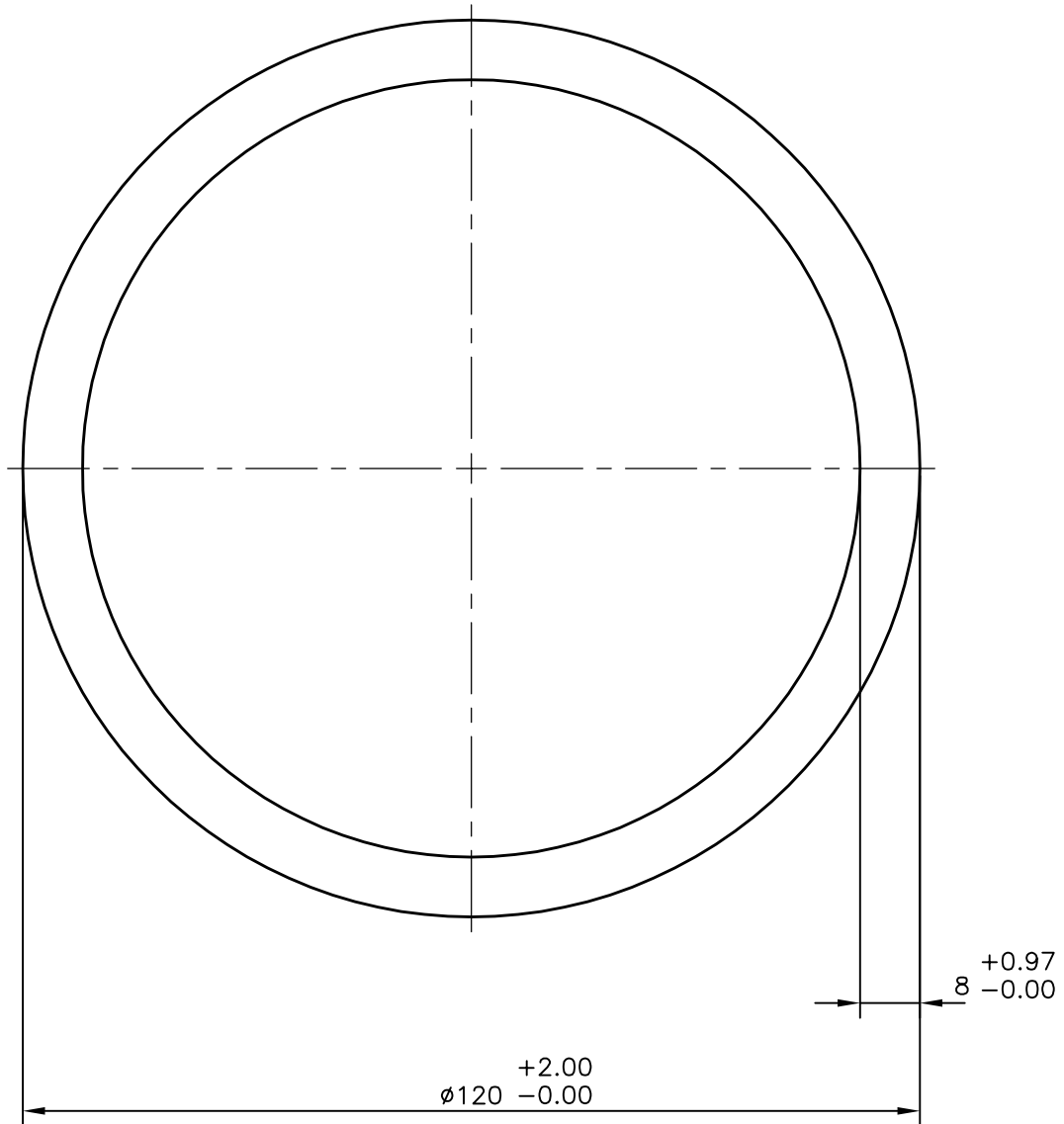

SYMBOL OF QUALITY
AN ISO 9001 COMPANY

JINDAL ALUMINIUM LTD.
BANGALORE-560073 (INDIA)

	NAME	DATE
DRAWN	PARVESH	07-02-2012
CHECKED		
APPROVED	S.S.GARG	28-02-2012
SCALE		1:1
AREA mm ²		2814.867
PERIMETER mm.		376.991
WEIGHT kg/m		7.6
DRAWING No.	SECTION No.	
P-11399-1		
S3203	S3203	
13586	13586	

1. ALL DIMENSIONS ARE IN mm.
2. ROUND OFF ALL SHARP CORNERS WITH 0.40 mm.
3. TOLERANCES WILL BE AS PER IS:2673-2002 , UNLESS OTHERWISE SPECIFIED

PARTY'S NAME	WELD TECH ENGINEERS & FABRICATORS, AURANGABAD
PARTY'S DRAWING No.	AS PER SPECIFICATION
ALLOY & TEMPER	63400 WP
DESCRIPTION	ROUND TUBE