

P-13002

S3859

13591

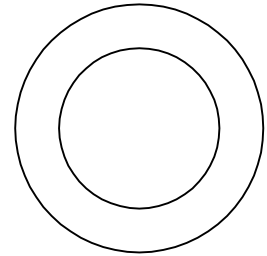

SCALE: - 1:1

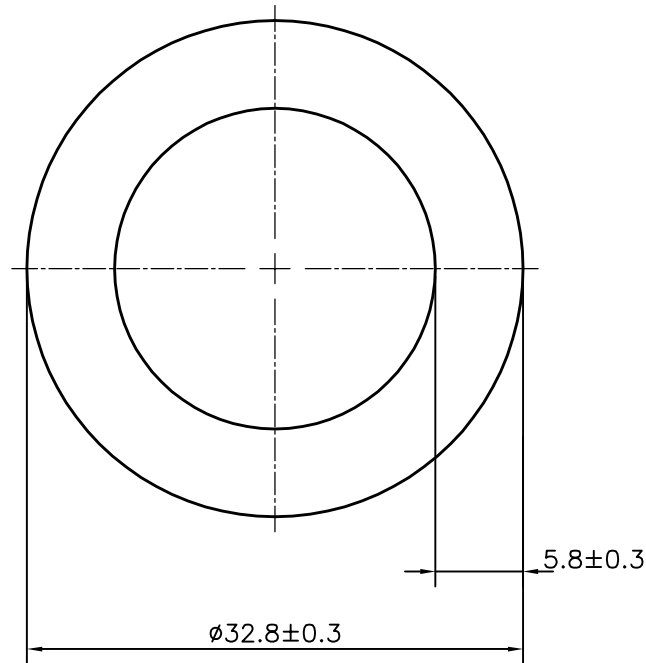
**ISSUE-2 :-**

- ☞ OD DIMENSION CHANGE FROM  $\phi 32$  TO  $\phi 32.8$ mm.
- ☞ THICKNESS CHANGED FROM 5.6 TO 6 mm.
- ☞ WEIGHT ALSO CHANGED FROM 1.254 TO 1.364 Kg/m.

**ISSUE-3 :-**

- ☞ THICKNESS CHANGED FROM 6 TO 5.8 mm.
- ☞ WEIGHT ALSO CHANGED FROM 1.364 TO 1.328 Kg/m.



SYMBOL OF QUALITY  
AN ISO 9001 COMPANY

**JINDAL ALUMINIUM LTD.**  
BANGALORE-560073 (INDIA)

	NAME	DATE
DRAWN	PARVESH	23-01-2014
CHECKED		
APPROVED	S.S.GARG	14-02-2014
SCALE		2:1
AREA mm <sup>2</sup>		491.973
PERIMETER mm.		103.044
WEIGHT kg/m		1.328
DRAWING No.		SECTION No.
P-13002		-
S3859		S3859 (ISSUE-3)
13591		13591

1. ALL DIMENSIONS ARE IN mm.
2. ROUND OFF ALL SHARP CORNERS WITH 0.40 mm.
3. TOLERANCES WILL BE AS PER,IS:2673-2002 UNLESS OTHERWISE SPECIFIED

PARTY'S NAME SUBROS LTD., GURGAON

PARTY'S DRAWING No. 13483

ALLOY & TEMPER DA3103BD M

DESCRIPTION ROUND TUBE