

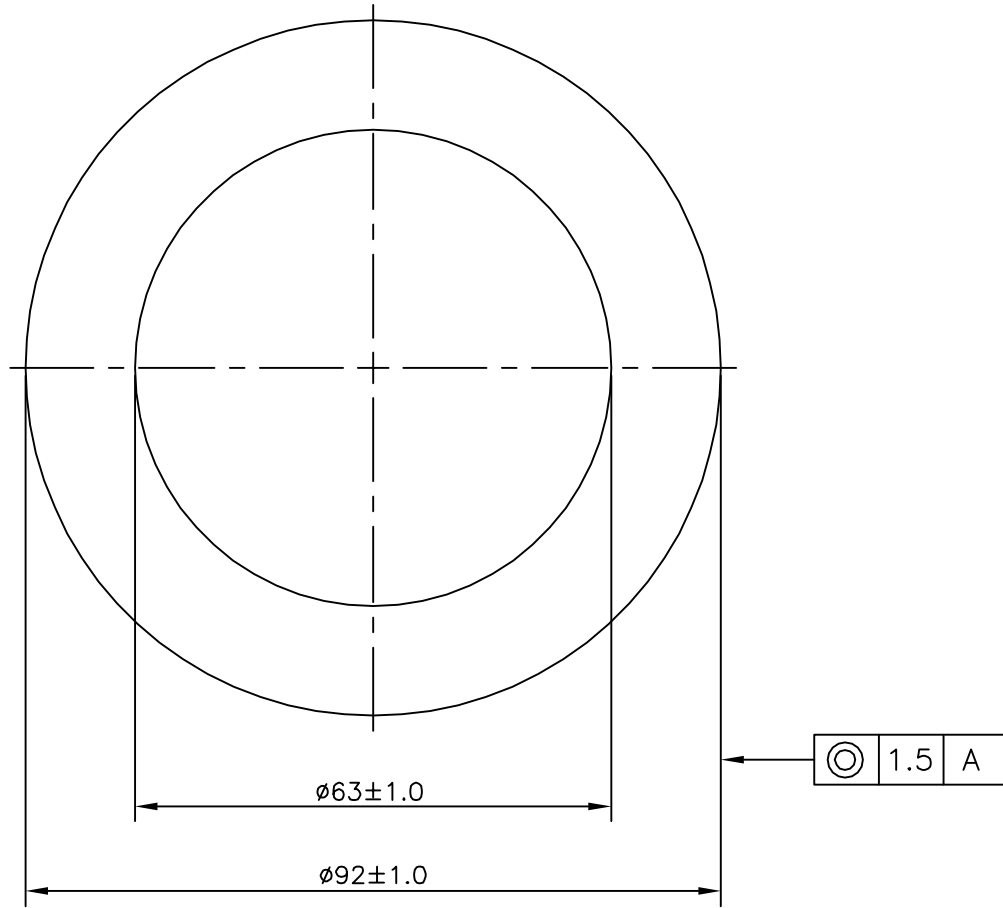

P-12013-1

S3523

13611



STRAIGHTNESS = 1.00mm/M

 SYMBOL OF QUALITY AN ISO 9001 COMPANY	JINDAL ALUMINIUM LTD. <i>BANGALORE-560073 (INDIA)</i>		NAME	DATE
		DRAWN	RAGHAVENDRA	22-09-2012
1. ALL DIMENSIONS ARE IN mm. 2. ROUND OFF ALL SHARP CORNERS WITH 0.40 mm. 3. TOLERANCES WILL BE AS PER IS:2673-2002 UNLESS OTHERWISE SPECIFIED		CHECKED		
		APPROVED	S.S.GARG	29-10-2012
PARTY'S NAME HIWIN TECHNOLOGIES INDIA PVT. LTD., COIMBATORE		SCALE		1:1
		AREA mm ²		3530.365
PARTY'S DRAWING No. F53B10		PERIMETER mm.		289.027
		WEIGHT kg/m		9.532
ALLOY & TEMPER 6101B T7		DRAWING No.	SECTION No.	
		P-12013-1	-	
DESCRIPTION ROUND TUBE		S3523		S3523
		13611		13611