

P-14310

S4345

13620

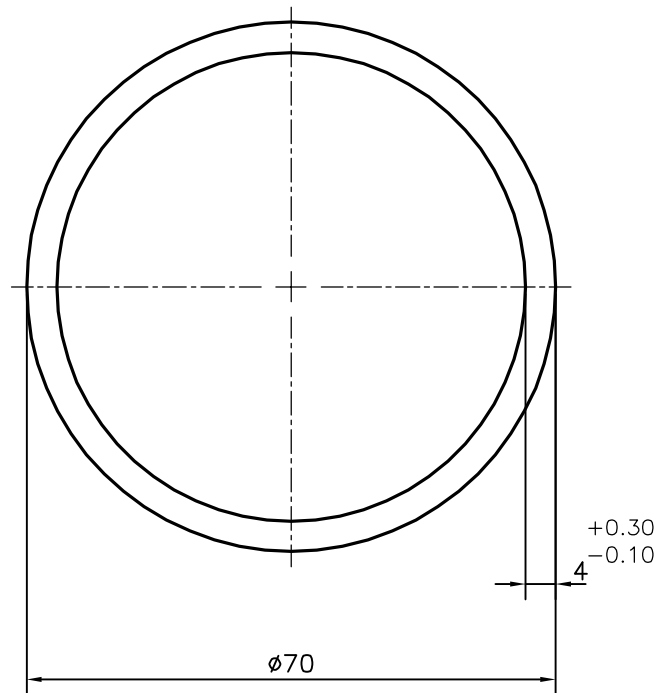

ISSUE-2

TOLERANCE ADDED ON THICKNESS $4.0^{+0.30}_{-0.10}$ 

SYMBOL OF QUALITY
AN ISO 9001 COMPANY

JINDAL ALUMINIUM LTD.
BANGALORE-560073 (INDIA)

	NAME	DATE
DRAWN	J.P.KAUSHIK	29-01-2015
CHECKED		
APPROVED	S.S.GARG	29-01-2015
SCALE		1:1
AREA mm ²		829.38
PERIMETER mm.		219.911
WEIGHT kg/m		2.239
DRAWING No.		SECTION No.
P-14310		-
S4345		S4345(ISSUE-2)
13620		13620

1. ALL DIMENSIONS ARE IN mm.
2. ROUND OFF ALL SHARP CORNERS WITH 0.40 mm.
3. TOLERANCES WILL BE AS PER IS:2673-2002 , UNLESS OTHERWISE SPECIFIED

PARTY'S NAME	S.J CONTRACTS PVT. LTD., PUNE
PARTY'S DRAWING No.	AS PER SPECIFICATION
ALLOY & TEMPER	6082 T6
DESCRIPTION	ROUND TUBE