

P-12652-1

S3827

13634

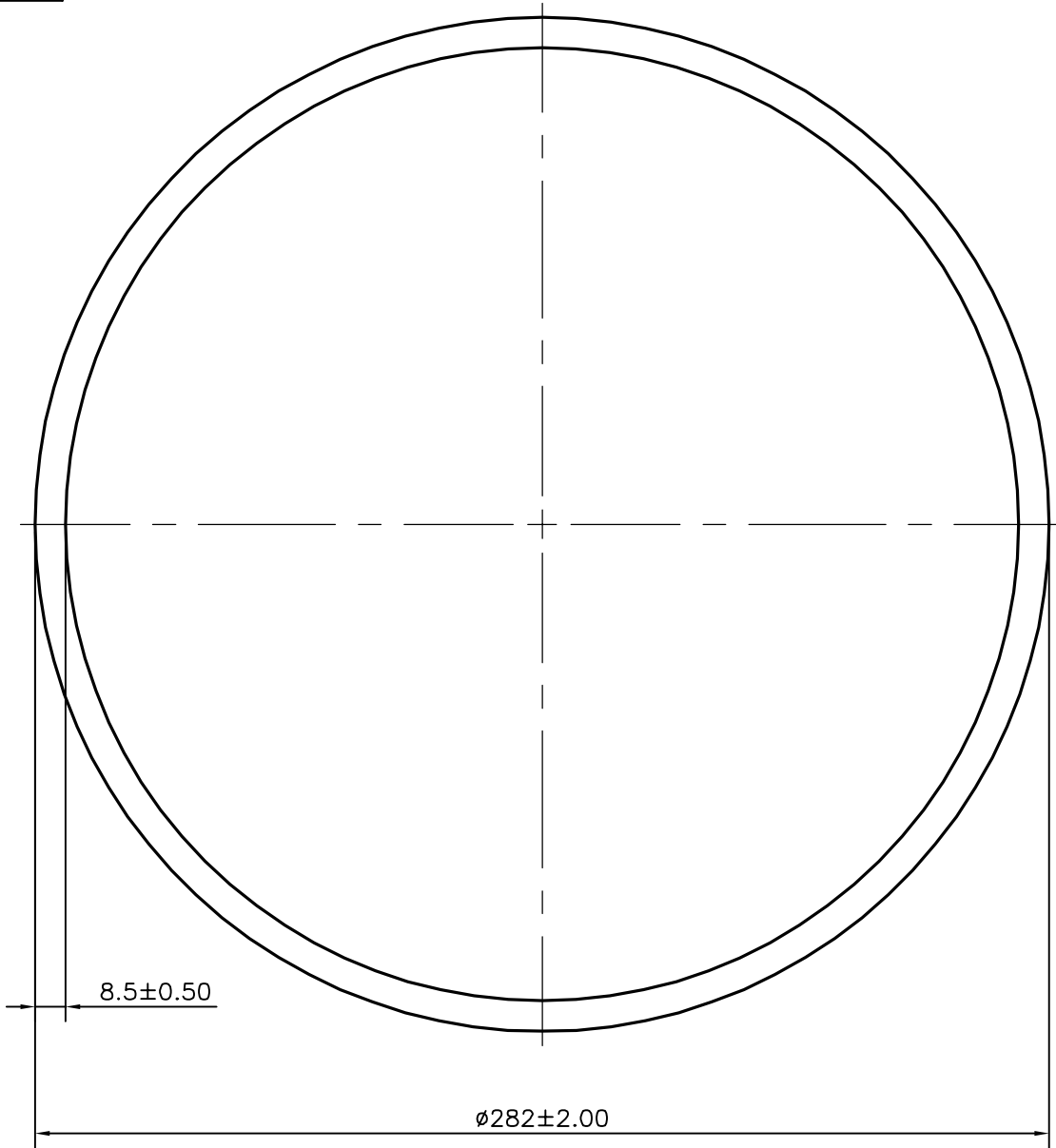

TOLERANCES ON OVERALL WIDTHS & WIDTHS ACROSS FLATS OF BARS, & REGULAR SECTIONS

| | | | |
|---------------------|----------------------|----------------------|-----------------------|
| UPTO 6.40mm - ±0.20 | UPTO 32.0mm - ±0.38 | UPTO 120.0mm - ±0.85 | UPTO 320.00mm - ±1.70 |
| UPTO 10.0mm - ±0.23 | UPTO 50.0mm - ±0.46 | UPTO 160.0mm - ±1.02 | |
| UPTO 12.0mm - ±0.25 | UPTO 60.0mm - ±0.53 | UPTO 200.0mm - ±1.14 | |
| UPTO 16.0mm - ±0.28 | UPTO 80.0mm - ±0.69 | UPTO 250.0mm - ±1.40 | |
| UPTO 25.0mm - ±0.30 | UPTO 100.0mm - ±0.75 | UPTO 300.0mm - ±1.65 | |



SYMBOL OF QUALITY
AN ISO 9001 COMPANY

JINDAL ALUMINIUM LTD.
BANGALORE-560073 (INDIA)

| | NAME | DATE |
|----------|-----------|------------|
| DRAWN | SRIVATHSA | 20-07-2013 |
| CHECKED | | |
| APPROVED | S.S.GARG | 19-08-2013 |

1. ALL DIMENSIONS ARE IN mm.
2. ROUND OFF ALL SHARP CORNERS WITH 0.40 mm.
3. TOLERANCES WILL BE AS PER IS:2673-2002 ,UNLESS OTHERWISE SPECIFIED

| | |
|----------------------|----------|
| SCALE | 0.5:1 |
| AREA mm ² | 7303.418 |
| PERIMETER mm. | 885.929 |
| WEIGHT kg/m | 19.719 |

| | |
|---------------------|----------------------------------------|
| PARTY'S NAME | AVASARALA TECHNOLOGIES LTD., BANGALORE |
| PARTY'S DRAWING No. | AS PER SPECIFICATION & REQUIREMENT |
| ALLOY & TEMPER | 6061 T6 |
| DESCRIPTION | ROUND TUBE |

| DRAWING No. | SECTION No. |
|-------------|-------------|
| P-12652-1 | - |
| S3827 | S3827 |
| 13634 | 13634 |