

P-13079

S3894

13641

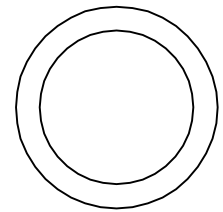

1:1

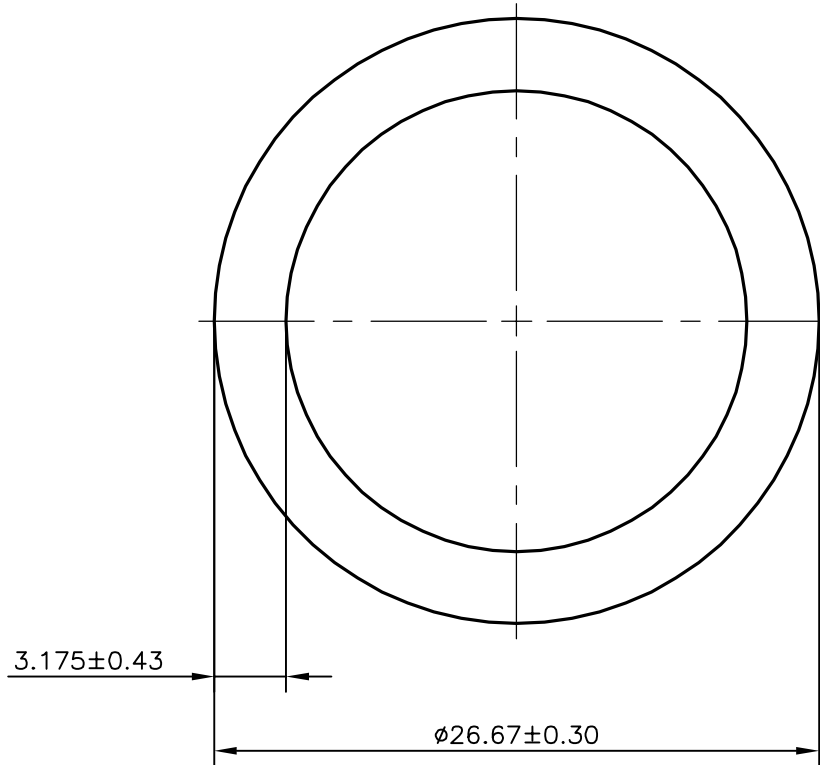

 SYMBOL OF QUALITY AN ISO 9001 COMPANY	JINDAL ALUMINIUM LTD. <i>BANGALORE-560073 (INDIA)</i>	NAME		DATE
		DRAWN	<i>SRIVATHSA</i>	07-10-2013
1. ALL DIMENSIONS ARE IN mm. 2. ROUND OFF ALL SHARP CORNERS WITH 0.40 mm. 3. TOLERANCES WILL BE AS PER IS:2673-2002, UNLESS OTHERWISE SPECIFIED		CHECKED		
		APPROVED	<i>S.S.GARG</i>	15-10-2013
PARTY'S NAME GBS MACHINE TOOLS INDUSTRIES., JALANDHAR		SCALE		3:1
		AREA mm ²		234.352
PARTY'S DRAWING No. 3/4 NPS		PERIMETER mm.		83.786
		WEIGHT kg/m		0.633
ALLOY & TEMPER 6063 T5		DRAWING No.		SECTION No.
		P-13079		-
DESCRIPTION ROUND TUBE		S3894		S3894
		13641		13641