

P-13090-1

S3904

13642

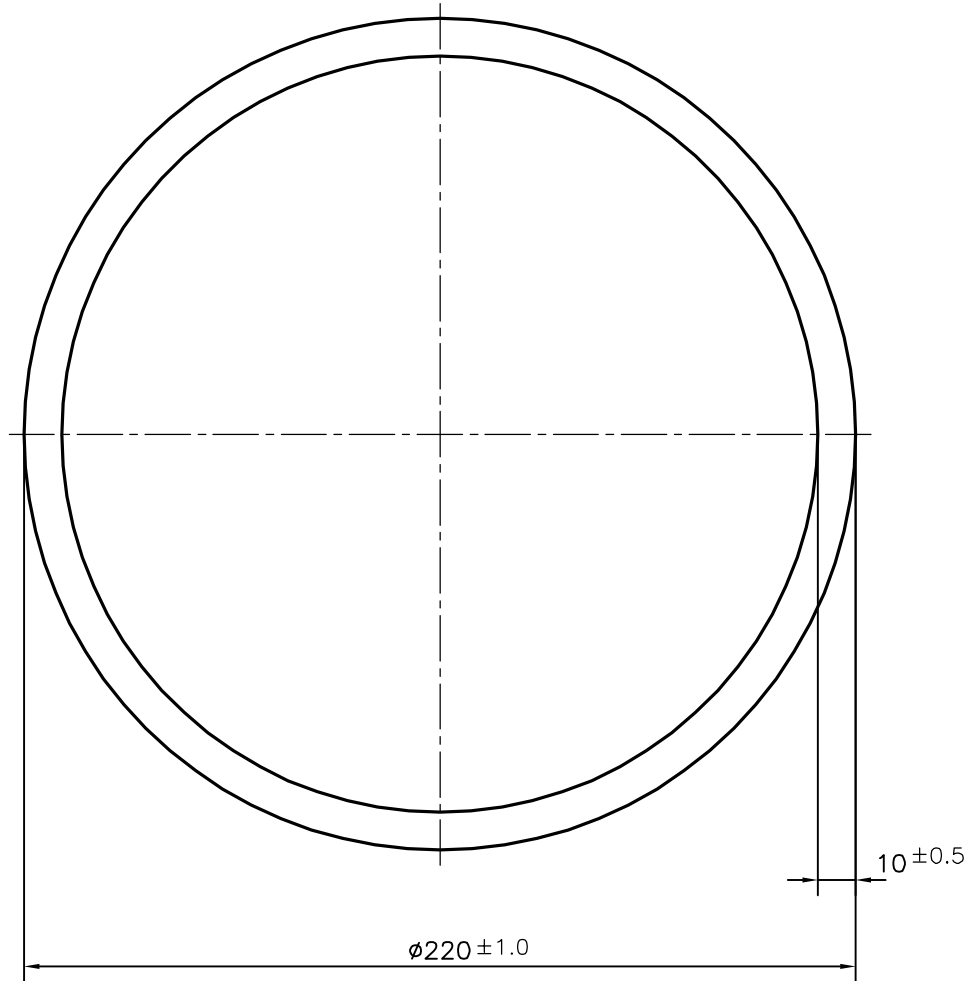

1. STRAIGHTNESS:- 1.2 mm/M
2. OVALITY :-  $\pm 2.2$  mm.



SYMBOL OF QUALITY  
AN ISO 9001 COMPANY

**JINDAL ALUMINIUM LTD.**  
*BANGALORE-560073 (INDIA)*

	NAME	DATE
DRAWN	PARVESH	18-10-2013
CHECKED		
APPROVED	S.S.GARG	20-10-2013
SCALE		0.5:1
AREA mm <sup>2</sup>		6597.345
PERIMETER mm.		691.15
WEIGHT kg/m		17.813
DRAWING No.	SECTION No.	
P-13090-1	-	
S3904	S3904	
13642	13642	

1. ALL DIMENSIONS ARE IN mm.
2. ROUND OFF ALL SHARP CORNERS WITH 0.40 mm.
3. TOLERANCES WILL BE AS PER IS:2673-2002 , UNLESS OTHERWISE SPECIFIED

PARTY'S NAME	POWERGEAR LTD., BANGALORE
PARTY'S DRAWING No.	AS PER SPECIFICATION
ALLOY & TEMPER	63401 WP (AS PER IS-5082)
DESCRIPTION	ROUND TUBE