

P-13345-1

S4016

13656

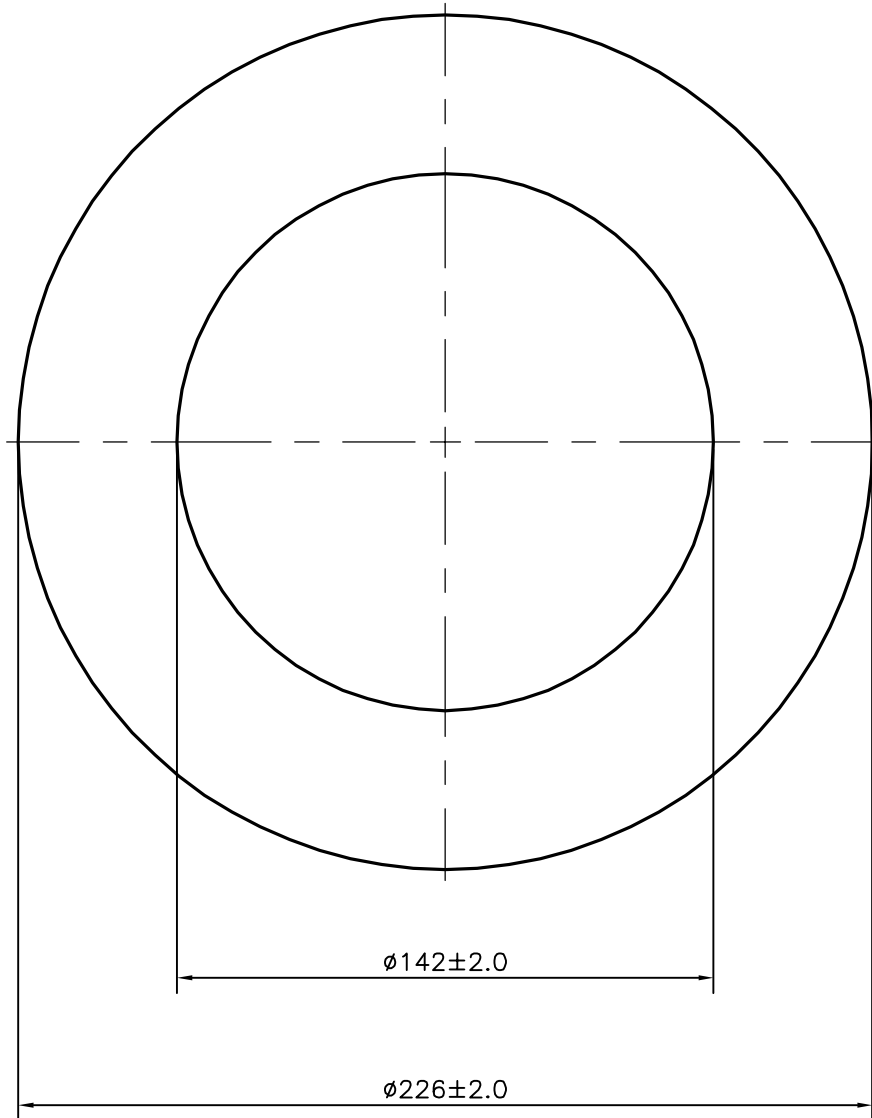

STRAIGHTNESS=1.2mm/M
 OVALTY ± 2.0 mm

ISSUE-2:- DIMENSION CHANGED FROM $\phi 224$ mm TO $\phi 226$ mm
 WEIGHT ALSO CHANGED 63.643 kg/M TO 65.551 kg/M

 SYMBOL OF QUALITY AN ISO 9001 COMPANY	JINDAL ALUMINIUM LTD. BANGALORE-560073 (INDIA)	NAME		DATE
		DRAWN	J.P.KAUSHIK	02-04-2014
1. ALL DIMENSIONS ARE IN mm. 2. ROUND OFF ALL SHARP CORNERS WITH 0.40 mm. 3. TOLERANCES WILL BE AS PER IS:6477-1983 , UNLESS OTHERWISE SPECIFIED		CHECKED		
		APPROVED	S.S.GARG	15-04-2014
PARTY'S NAME RABWIN INDUSTRIES PVT. LTD., COIMBATORE		SCALE		0.5:1
		AREA mm ²		24278.228
PARTY'S DRAWING No. AS PER SPECIFICATION		PERIMETER mm.		710
		WEIGHT kg/m		65.551
ALLOY & TEMPER 6082 T6		DRAWING No.	SECTION No.	
		P-13345-1	-	
DESCRIPTION ROUND TUBE		S4016	S4016(ISSUE-2)	
		13656	13656	