

P-15251

S4722

13698

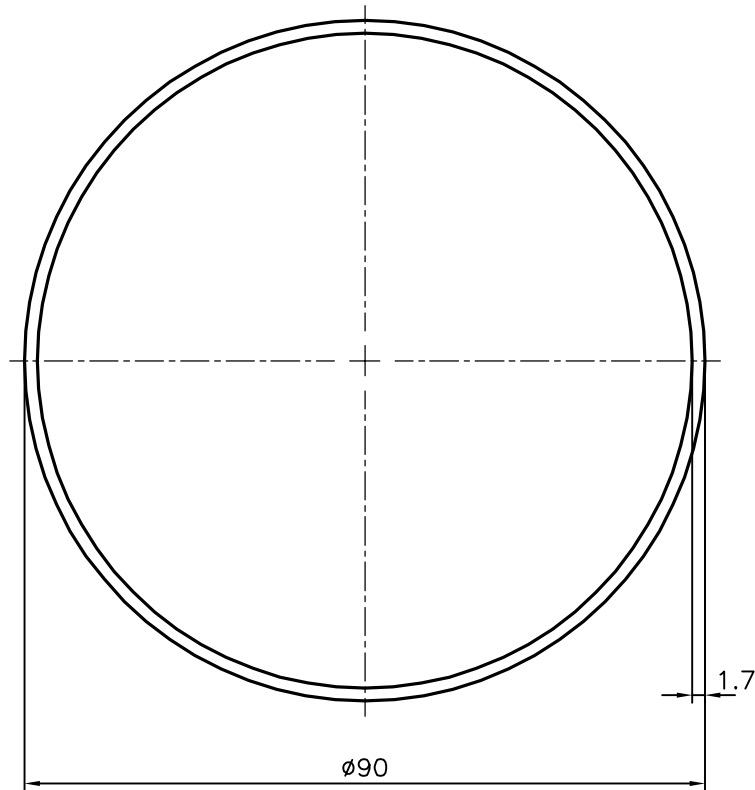

SYMBOL OF QUALITY
AN ISO 9001 COMPANY

JINDAL ALUMINIUM LTD.
BANGALORE-560073 (INDIA)

	NAME	DATE
DRAWN	J.P.KAUSHIK	27-10-2015
CHECKED		
APPROVED	S.S.GARG	07-11-2015
SCALE		1:1
AREA mm ²		471.584
PERIMETER mm.		282.743
WEIGHT kg/m		1.273
DRAWING No.	SECTION No.	
P-15251	-	
S4722	S4722	
13698	13698	

1. ALL DIMENSIONS ARE IN mm.
2. ROUND OFF ALL SHARP CORNERS WITH 0.40 mm.
3. TOLERANCES WILL BE AS PER IS:2673-2002, UNLESS OTHERWISE SPECIFIED

PARTY'S NAME	NASH INDUSTRIES (INDIA) PVT. LTD., BANGALORE
PARTY'S DRAWING No.	AS PER SPECIFICATION
ALLOY & TEMPER	EN-1050F
DESCRIPTION	ROUND TUBE