

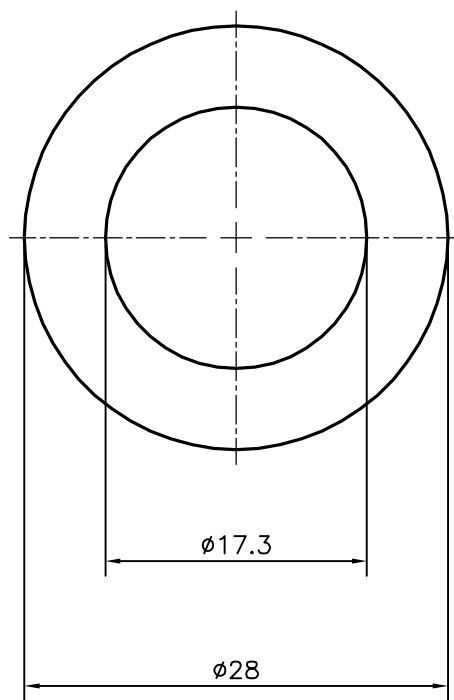

P-15517
S4831
13705

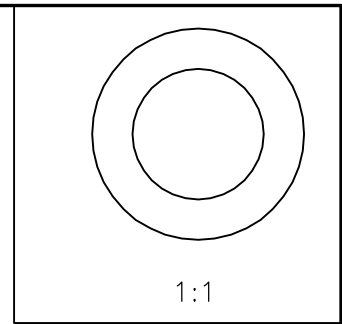

 SYMBOL OF QUALITY AN ISO 9001 COMPANY	<b>JINDAL ALUMINIUM LTD.</b> <i>BANGALORE-560073 (INDIA)</i>		NAME	DATE
		DRAWN	J.P.KAUSHIK	22-01-2016
1. ALL DIMENSIONS ARE IN mm. 2. ROUND OFF ALL SHARP CORNERS WITH 0.40 mm. 3. TOLERANCES WILL BE AS PER,IS:2673-2002 UNLESS OTHERWISE SPECIFIED		CHECKED		
		APPROVED	S.S.GARG	27-01-2016
PARTY'S NAME S.S.INDUSTRIES, BANGALORE		SCALE		2:1
		AREA mm <sup>2</sup>		380.69
PARTY'S DRAWING No. AS PER SPECIFICATION		PERIMETER mm.		87.965
		WEIGHT kg/m		1.028
ALLOY & TEMPER 6061 'O'		DRAWING No.		P-15517
		SECTION No.		-
DESCRIPTION ROUND TUBE		S4831		S4831
		13705		13705