

P-16700-1

S5284

13720

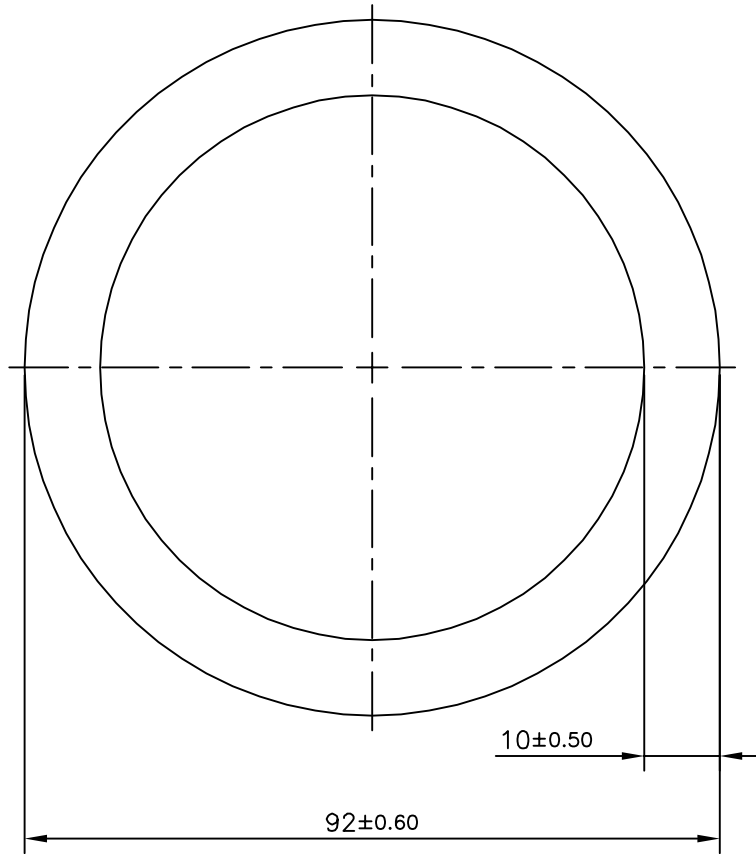

ECCENTRICITY : ±0.5 mm



SYMBOL OF QUALITY
AN ISO 9001 COMPANY

JINDAL ALUMINIUM LTD.
BANGALORE-560073 (INDIA)

	NAME	DATE
DRAWN	KIRAN	18-01-2017
CHECKED		
APPROVED	B.NATARAJ	02-02-2017
SCALE		1:1
AREA mm ²		2576.106
PERIMETER mm.		289.027
WEIGHT kg/m		6.955
DRAWING No.	SECTION No.	
P-16700-1		
S5284	S5284	
13720	13720	

1. ALL DIMENSIONS ARE IN mm.
2. ROUND OFF ALL SHARP CORNERS WITH 0.50 mm.
3. TOLERANCES WILL BE AS PER BS:EN-755-8, UNLESS OTHERWISE SPECIFIED

PARTY'S NAME	RABWIN INDUSTRIES PVT. LTD., COIMBATORE
PARTY'S DRAWING No.	F465165 REV-01
ALLOY & TEMPER	6101 BT7
DESCRIPTION	ROUND TUBE