

P-18148-1

S5817

13729

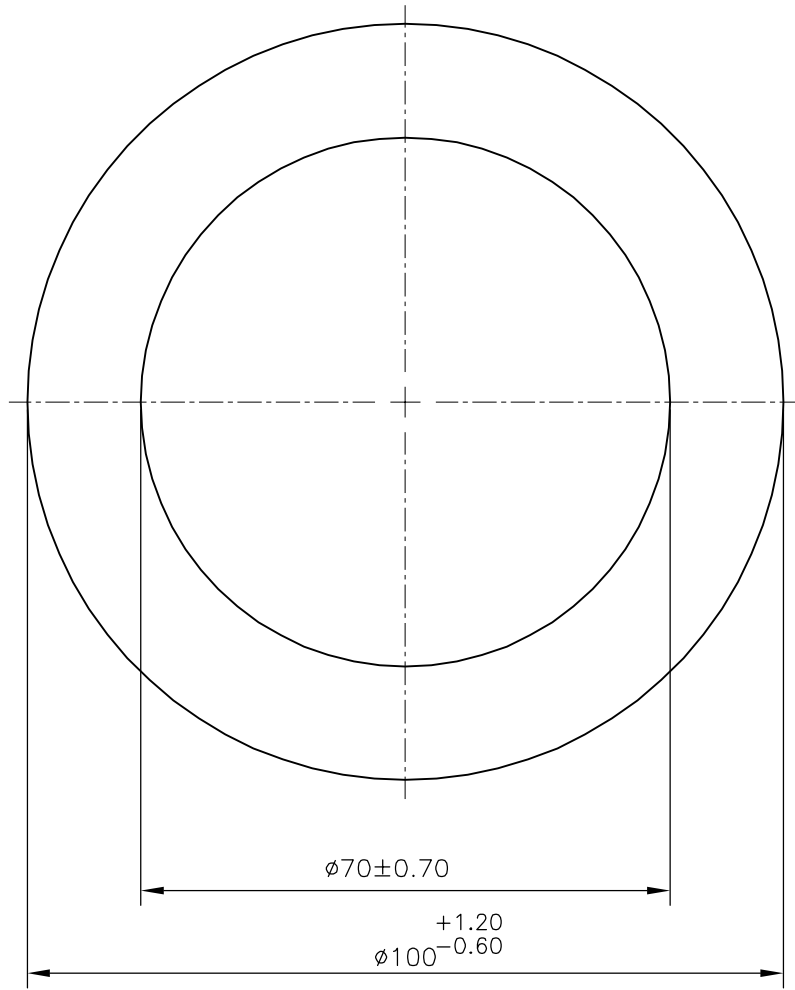

1. STRAIGHTNESS=1.7mm/M



SYMBOL OF QUALITY  
AN ISO 9001 COMPANY

**JINDAL ALUMINIUM LTD.**  
BANGALORE-560073 (INDIA)

	NAME	DATE
DRAWN	J.P.KAUSHIK	30-04-2018
CHECKED		
APPROVED	B.NATARAJA	07-05-2018
SCALE		1:1
AREA mm <sup>2</sup>		4005.531
PERIMETER mm.		314.159
WEIGHT kg/m		10.815
DRAWING No.		SECTION No.
P-18148-1		-
S5817		S5817
13729		13729

1. ALL DIMENSIONS ARE IN mm.
2. ROUND OFF ALL SHARP CORNERS WITH 0.40 mm.
3. TOLERANCES WILL BE AS PER IS:2673-2002 , UNLESS OTHERWISE SPECIFIED

PARTY'S NAME	NEELAY INDUSTRIES, NASHIK
PARTY'S DRAWING No.	AS PER SPECIFICATION
ALLOY & TEMPER	6063 T6
DESCRIPTION	ROUND TUBE