

P-16753-1

S5280

13736

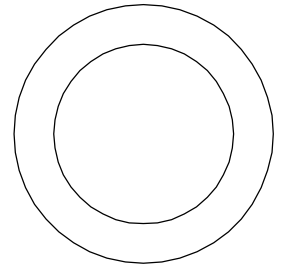

SCALE 1:1

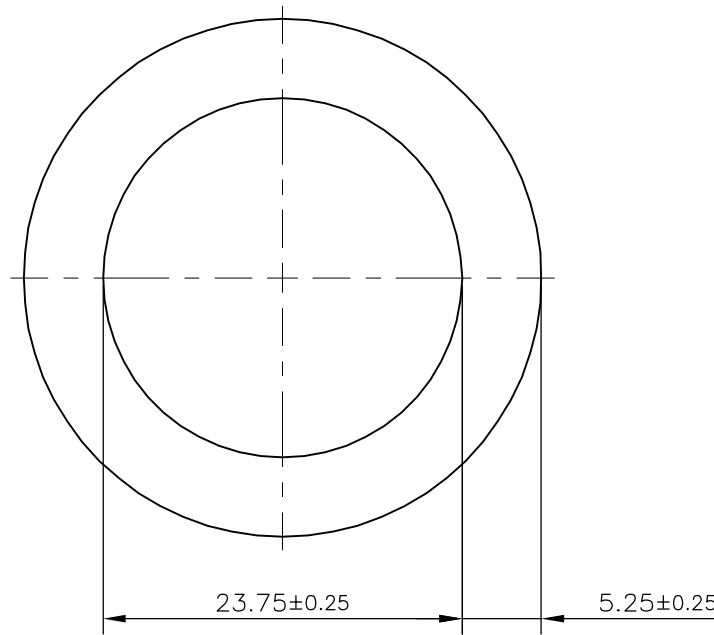

SYMBOL OF QUALITY
AN ISO 9001 COMPANY

JINDAL ALUMINIUM LTD.
BANGALORE-560073 (INDIA)

	NAME	DATE
DRAWN	KIRAN	24-01-2017
CHECKED		
APPROVED	B.NATARAJ	28-01-2017

1. ALL DIMENSIONS ARE IN mm.
2. ROUND OFF ALL SHARP CORNERS WITH 0.50 mm.
3. TOLERANCES WILL BE AS PER IS:2673-2002, UNLESS OTHERWISE SPECIFIED

SCALE	2:1
AREA mm ²	478.307
PERIMETER mm.	107.6
WEIGHT kg/m	1.291

PARTY'S NAME	3D ENGINEERS, THANE
PARTY'S DRAWING No.	AS PER SPECIFICATION & REQUIREMENT
ALLOY & TEMPER	19501 'M'
DESCRIPTION	ROUND TUBE

DRAWING No.	SECTION No.
P-16753-1	
S5280	S5280
13736	13736