

P-19522

13737

EXPOSED SURFACE

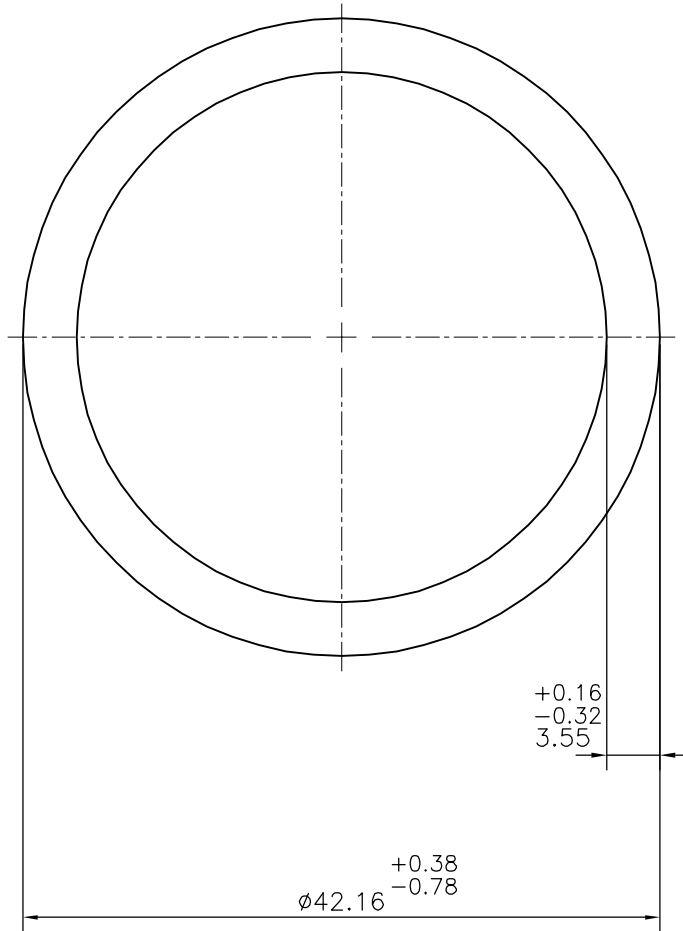
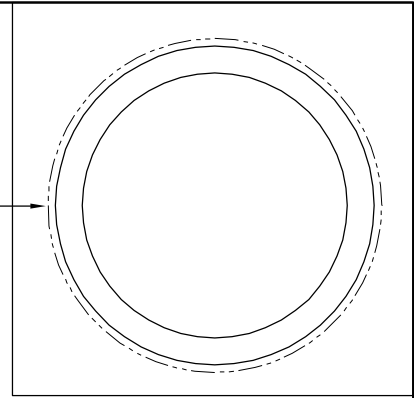

SYMBOL OF QUALITY
AN ISO 9001 COMPANY

JINDAL ALUMINIUM LTD.
BANGALORE-560073 (INDIA)

	NAME	DATE
DRAWN	J.P.KAUSHIK	08-05-2019
CHECKED		
APPROVED	B.NATARAJA	13-05-2019
SCALE		2:1
AREA mm ²		430.604
PERIMETER mm.		132.45
WEIGHT kg/m		1.163
DRAWING No.	SECTION No.	
P-19522	-	
13737	13737	

1. ALL DIMENSIONS ARE IN mm.
2. ROUND OFF ALL SHARP CORNERS WITH 0.40 mm.
3. TOLERANCES WILL BE AS PER ANSI:H35.2-2009, UNLESS OTHERWISE SPECIFIED

PARTY'S NAME	FLODRIA ALUMINIUM, USA
PARTY'S DRAWING No.	FH-00622
ALLOY & TEMPER	6063 T52
DESCRIPTION	ROUND TUBE