

P-17263

S5559

13757

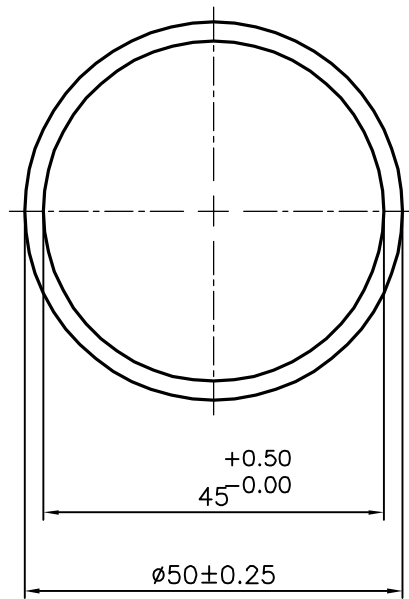

SYMBOL OF QUALITY
AN ISO 9001 COMPANY

JINDAL ALUMINIUM LTD.
BANGALORE-560073 (INDIA)

	NAME	DATE
DRAWN	J.P.KAUSHIK	14-06-2017
CHECKED		
APPROVED	B.NATARAJA	04-11-2017
SCALE		1:1
AREA mm ²		373.064
PERIMETER mm.		157.08
WEIGHT kg/m		1.007
DRAWING No.		SECTION No.
P-17263		-
S5559		S5559
13757		13757

1. ALL DIMENSIONS ARE IN mm.
2. ROUND OFF ALL SHARP CORNERS WITH 0.40 mm.
3. TOLERANCES WILL BE AS PER IS:2673-2002 , UNLESS OTHERWISE SPECIFIED

PARTY'S NAME	PERMALI WALLACE PVT. LTD., BHOPAL
PARTY'S DRAWING No.	AS PER SPECIFICATION
ALLOY & TEMPER	HE30 WP
DESCRIPTION	ROUND TUBE