

P-21767

13784

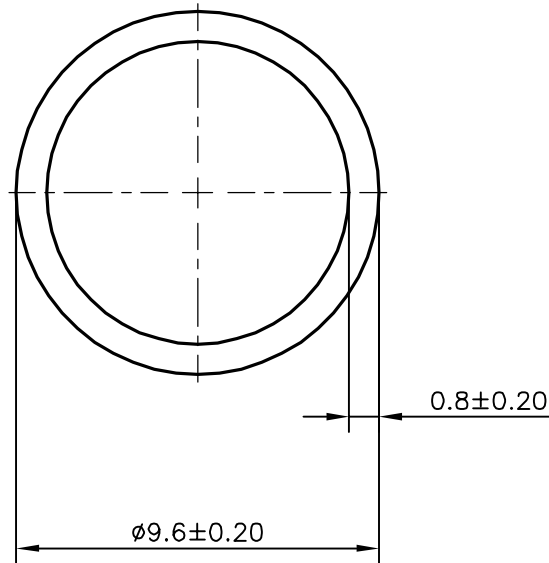

1:1



APPROXIMATE WEIGHT RANGE - 0.045 - 0.075 kg/m



SYMBOL OF QUALITY
AN ISO 9001 COMPANY

JINDAL ALUMINIUM LTD.
BANGALORE-560073 (INDIA)

	NAME	DATE
DRAWN	J.P.KAUSHIK	10-11-2020
CHECKED		
APPROVED	B.NATARAJA	08-12-2020

1. ALL DIMENSIONS ARE IN mm.
2. ROUND OFF ALL SHARP CORNERS WITH 0.40 mm.
3. TOLERANCES WILL BE AS PER IS:2673-2002 UNLESS OTHERWISE SPECIFIED

SCALE	5:1
AREA mm ²	22.117
PERIMETER mm.	30.159
WEIGHT kg/m	0.060

PARTY'S NAME A.R.INDUSTRIES, SIRMOUR

DRAWING No. SECTION No.

PARTY'S DRAWING No. AS PER SPECIFICATION

P-21767

-

ALLOY & TEMPER E1E 'M'

13784

13784

DESCRIPTION

ROUND TUBE