

P-21691

13785

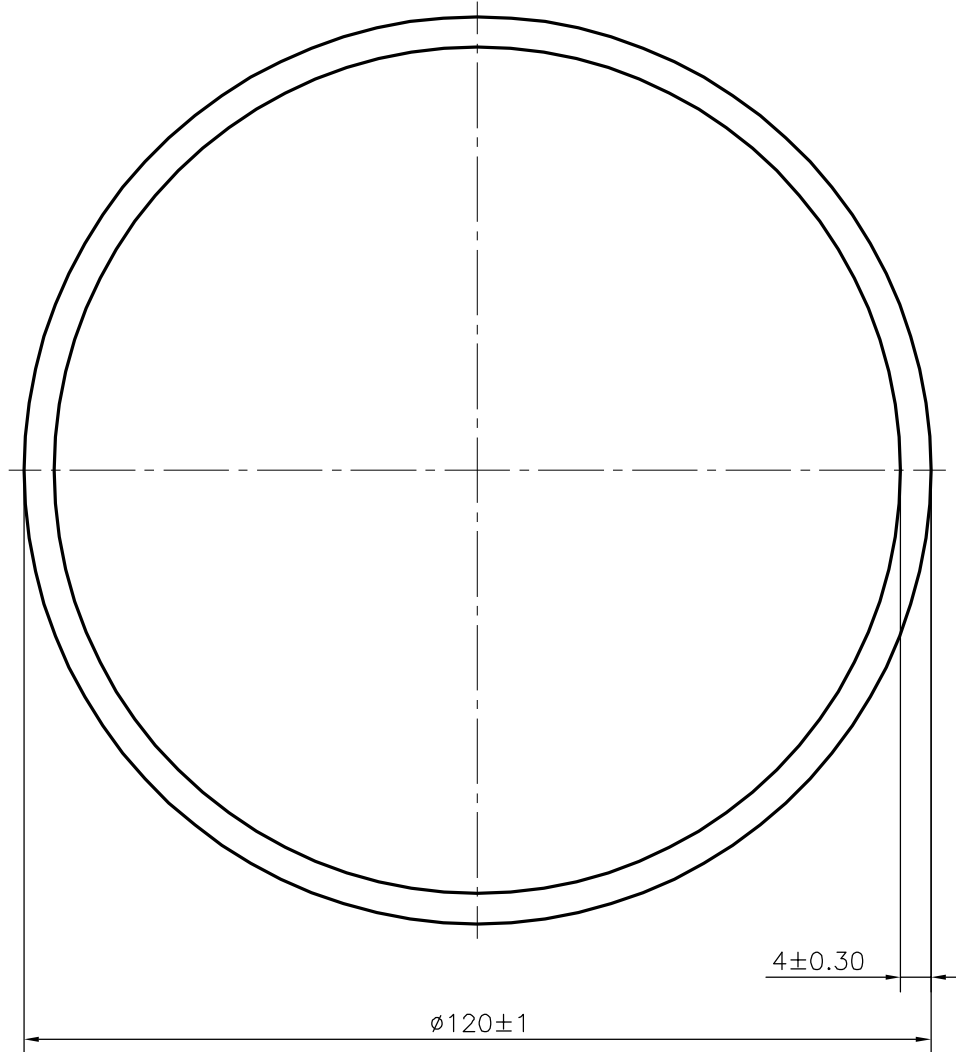

**WEIGHT RANGE (kg/m) - 3.542 - 4.330 (APPROX.)**

**FINISH:- ANODIZING**

1. STRAIGHTNESS=1.7mm/M



SYMBOL OF QUALITY  
AN ISO 9001 COMPANY

**JINDAL ALUMINIUM LTD.**  
BANGALORE-560073 (INDIA)

	NAME	DATE
DRAWN	DARPAN	16-10-2020
CHECKED		
APPROVED	B.NATARAJA	11-12-2020
SCALE		1:1
AREA mm <sup>2</sup>		1457.699
PERIMETER mm.		376.991
WEIGHT kg/m		3.936
DRAWING No.		SECTION No.
P-21691		-
13785		13785

1. ALL DIMENSIONS ARE IN mm.
2. ROUND OFF ALL SHARP CORNERS WITH 0.40 mm.
3. TOLERANCES WILL BE AS PER IS:2673-2002 , UNLESS OTHERWISE SPECIFIED

PARTY'S NAME	SIDDHI ENGINEERS, AHMEDABAD
PARTY'S DRAWING No.	AS PER SPECIFICATION
ALLOY & TEMPER	6082 T4
DESCRIPTION	ROUND TUBE