

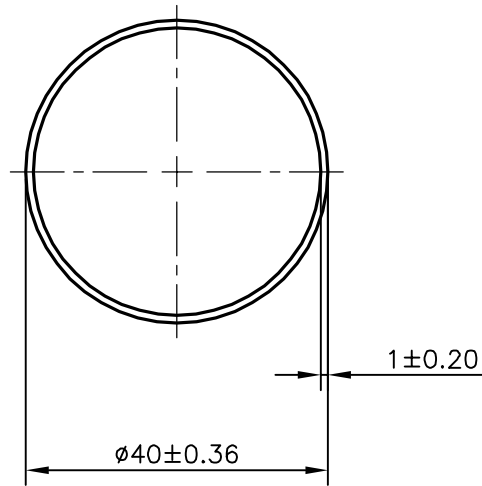

P-21764

13786



APPROXIMATE WEIGHT RANGE - 0.264 - 0.397 kg/m

 SYMBOL OF QUALITY AN ISO 9001 COMPANY	JINDAL ALUMINIUM LTD. BANGALORE-560073 (INDIA)		NAME	DATE
		DRAWN	J.P.KAUSHIK	10-11-2020
1. ALL DIMENSIONS ARE IN mm. 2. ROUND OFF ALL SHARP CORNERS WITH 0.40 mm. 3. TOLERANCES WILL BE AS PER IS:2673-2002 UNLESS OTHERWISE SPECIFIED		CHECKED		
		APPROVED	B.NATARAJA	11-12-2020
PARTY'S NAME SMIT INDUSTRIES, MUMBAI		SCALE		1:1
		AREA mm ²		122.522
PARTY'S DRAWING No. AS PER SPECIFICATION		PERIMETER mm.		125.664
		WEIGHT kg/m		0.331
ALLOY & TEMPER 19501 M		DRAWING No.	SECTION No.	
		P-21764	-	
DESCRIPTION ROUND TUBE		13786	13786	