

P-21811

13787

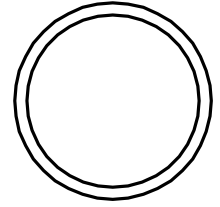

SCALE:- 1:1

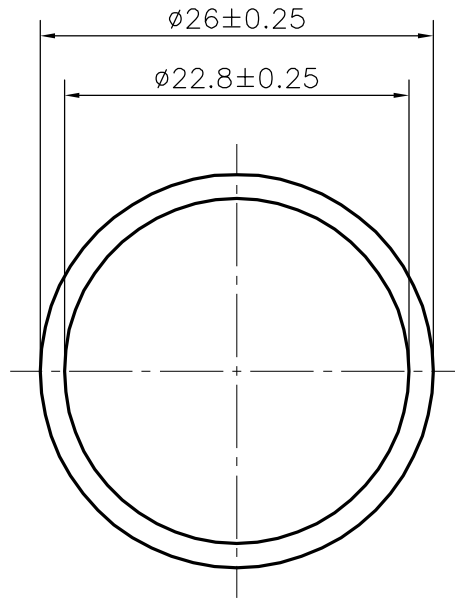

SCALE:- 2:1

APPROXIMATE WEIGHT RANGE - 0.279 - 0.383 kg/m



SYMBOL OF QUALITY
AN ISO 9001 COMPANY

JINDAL ALUMINIUM LTD.
BANGALORE-560073 (INDIA)

	NAME	DATE
DRAWN	DARPAN	30-11-2020
CHECKED		
APPROVED	B.NATARAJA	12-12-2020
SCALE		2:1
AREA mm ²		122.648
PERIMETER mm.		81.681
WEIGHT kg/m		0.331
DRAWING No.		SECTION No.
P-21811		-
13787		13787

1. ALL DIMENSIONS ARE IN mm.
2. ROUND OFF ALL SHARP CORNERS WITH 0.40 mm.
3. TOLERANCES WILL BE AS PER IS:2673-2002 , UNLESS OTHERWISE SPECIFIED

PARTY'S NAME	ATCO ALUMINIUM SYSTEMS, NEW DELHI
PARTY'S DRAWING No.	AS PER DRAWING
ALLOY & TEMPER	6063 T6
DESCRIPTION	ROUND TUBE