

P-10164

14917

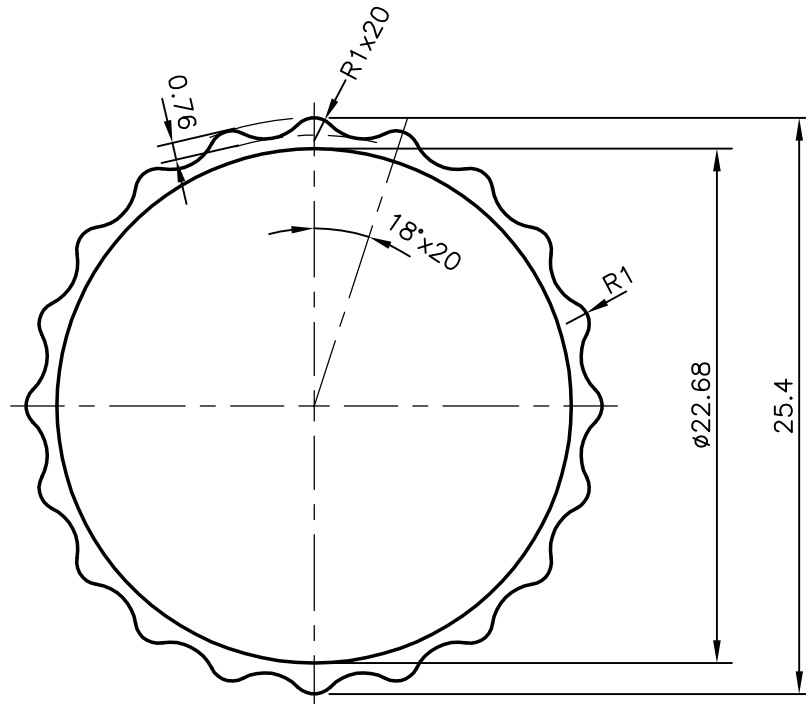

SYMBOL OF QUALITY  
AN ISO 9001 COMPANY

**JINDAL ALUMINIUM LTD.**  
BANGALORE-560073 (INDIA)

	NAME	DATE
DRAWN	J.P.KAUSHIK	06-07-2010
CHECKED		
APPROVED	S.S.GARG	14-07-2010
SCALE		3:1
AREA mm <sup>2</sup>		70.046
PERIMETER mm.		84.903
WEIGHT kg/m		0.189

1. ALL DIMENSIONS ARE IN mm.
2. ROUND OFF ALL SHARP CORNERS WITH 0.40 mm.
3. TOLERANCES WILL BE AS PER BS:EN-12020-2 UNLESS OTHERWISE SPECIFIED

PARTY'S NAME	GENERAL CATEGORY (DELHI MARKET)	DRAWING No.	SECTION No.
PARTY'S DRAWING No.	LIGHTER OF SECTION NO 14908	P-10164	-
ALLOY & TEMPER	HE9 WP	14917	14917
DESCRIPTION	FLUITED ROUND TUBE		