

P-13169

14918

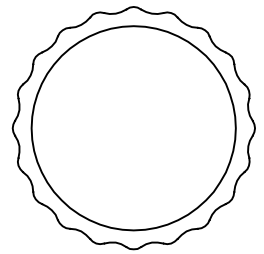

SCALE 1:1

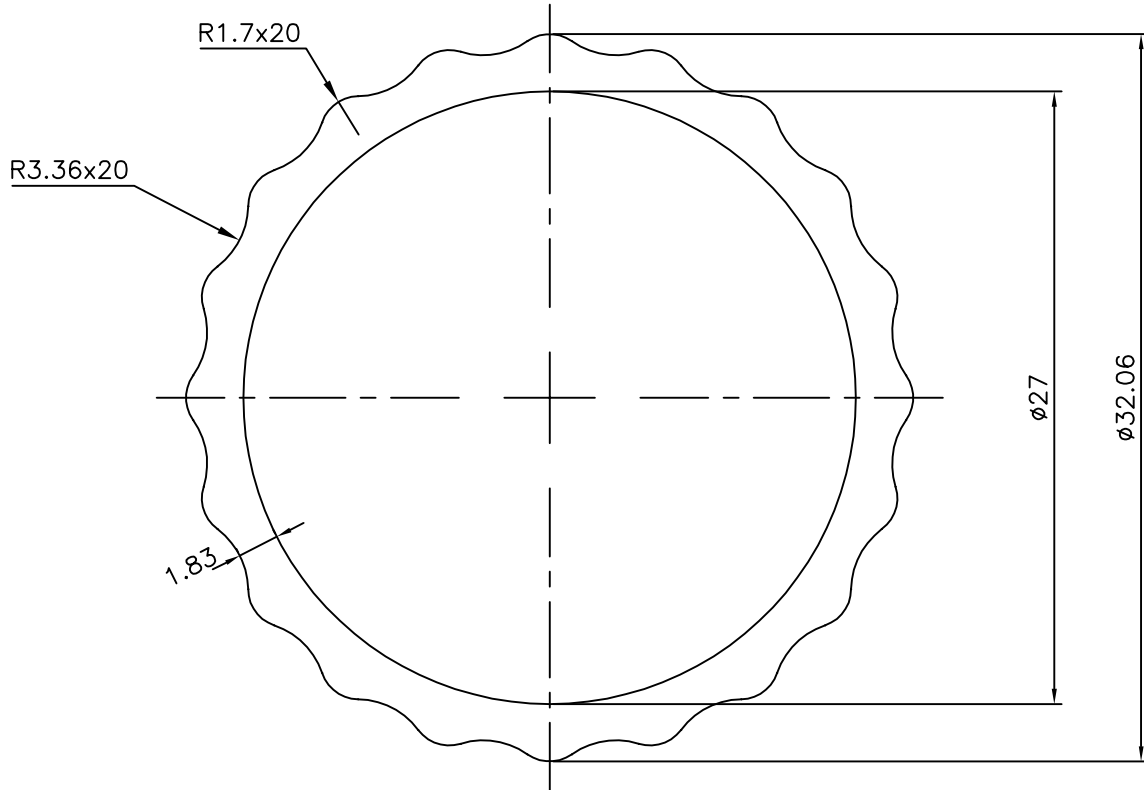

TOLERANCES ON OVERALL WIDTHS & WIDTHS ACROSS FLATS OF BARS, & REGULAR SECTIONS

UPTO 6.40mm - ± 0.20	UPTO 32.0mm - ± 0.38	UPTO 120.0mm - ± 0.85	UPTO 320.00mm - ± 1.70
UPTO 10.0mm - ± 0.23	UPTO 50.0mm - ± 0.46	UPTO 160.0mm - ± 1.02	
UPTO 12.0mm - ± 0.25	UPTO 60.0mm - ± 0.53	UPTO 200.0mm - ± 1.14	
UPTO 16.0mm - ± 0.28	UPTO 80.0mm - ± 0.69	UPTO 250.0mm - ± 1.40	
UPTO 25.0mm - ± 0.30	UPTO 100.0mm - ± 0.75	UPTO 300.0mm - ± 1.65	



SYMBOL OF QUALITY
AN ISO 9001 COMPANY

JINDAL ALUMINIUM LTD.
BANGALORE-560073 (INDIA)

	NAME	DATE
DRAWN	J.P.KAUSHIK	06-11-2013
CHECKED		
APPROVED	S.S.GARG	15-11-2013

1. ALL DIMENSIONS ARE IN mm.
2. ROUND OFF ALL SHARP CORNERS WITH 0.40 mm.
3. TOLERANCES WILL BE AS PER,IS:6477-1983 UNLESS OTHERWISE SPECIFIED

SCALE	3:1
AREA mm ²	197.37
PERIMETER mm.	103.576
WEIGHT kg/m	0.533

PARTY'S NAME	GENERAL CATEGORY, DELHI MARKET	DRAWING No.	P-13169	SECTION No.	-
PARTY'S DRAWING No.	AS PER DRAWING		14918		14918
ALLOY & TEMPER	HE9 WP				
DESCRIPTION	FLUTED ROUND TUBE				