

2755

15110

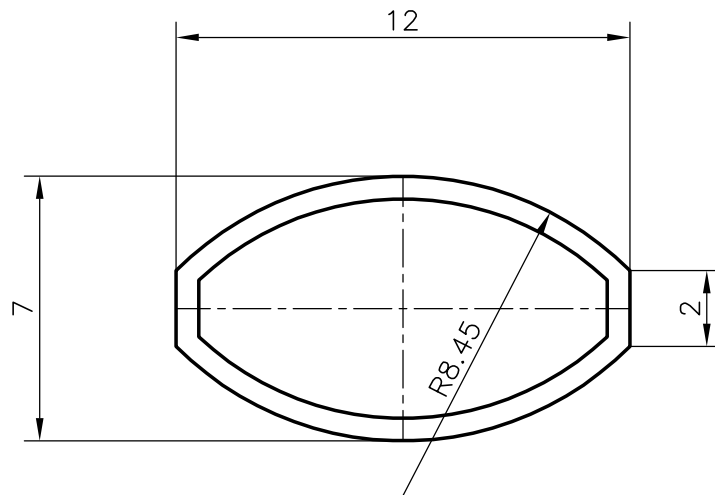

1:1



WALL THICKNESS :- 0.6 mm.

**JINDAL ALUMINIUM LTD.****BANGALORE-560073**

NAME

DATE

DRAWN

D.SRIVASTAVA

6.5.98

CHECKED

APPROVED

1. ALL DIMENSIONS ARE IN mm.  
 2. ROUND OFF ALL SHARP CORNERS WITH 0.4 mm.  
 3. TOLERANCES WILL BE AS PER IS: 6477-1983 ,UNLESS OTHERWISE SPECIFIED

PARTY'S NAME

GENERAL CATEGORY-MUMBAI MARKET

SCALE

5:1

PARTY'S DRAWING No.

SAMPLE

WEIGHT kg/m

0.047

ALLOY &amp; TEMPER

HE9 WP

SECTION No.

15110

LENGTH

AS REQUIRED

DRAWING No.

DESCRIPTION

BADMINTON SECTION

15110