

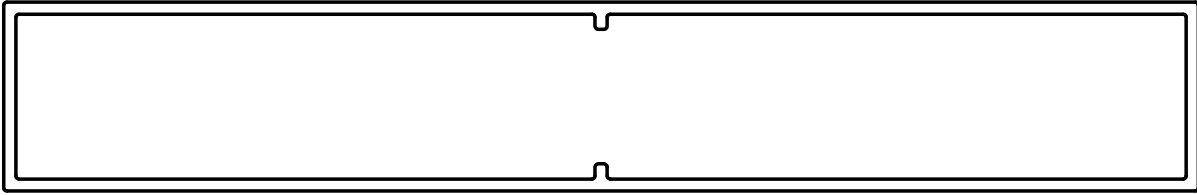

2774
10302
15118

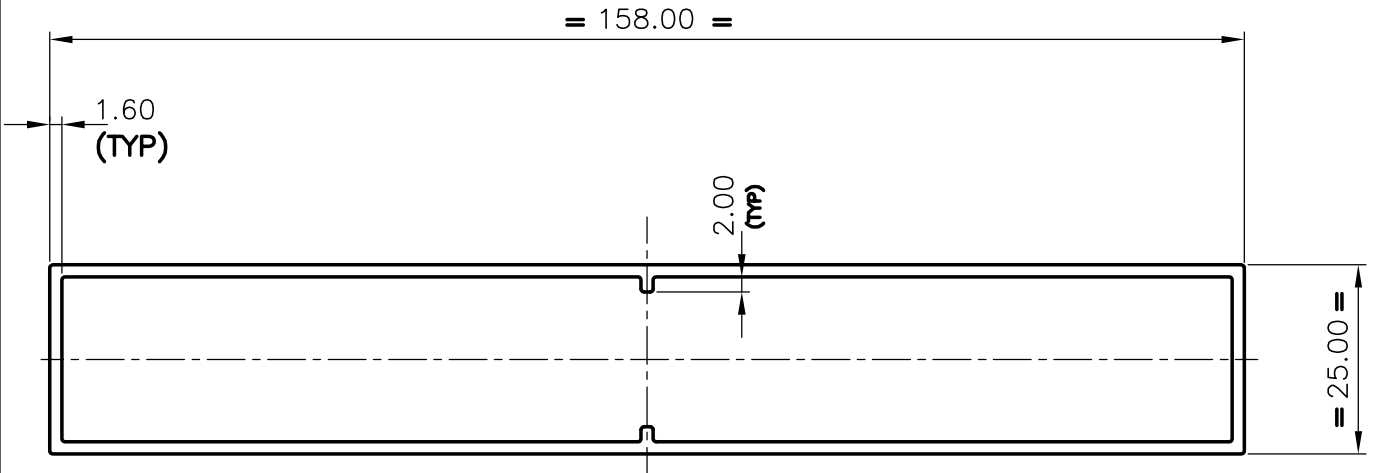

1:1 EXTRUDE VIEW



GENERAL WALL THICKNESS 1.60 mm

 SYMBOL OF QUALITY AN ISO 9002 COMPANY	JINDAL ALUMINIUM LTD. BANGALORE-560073 (INDIA)		NAME	DATE
		DRAWN	P,KULKARNI	14-8-2000
1. ALL DIMENSIONS ARE IN mm. 2. ROUND OFF ALL SHARP CORNERS WITH 0.40 mm. 3. TOLERANCES WILL BE AS PER I.S: 6477-1983 UNLESS OTHERWISE SPECIFIED		CHECKED		
		APPROVED		
		SCALE	1:1	
PARTY'S NAME	GENERAL CATEGORY (MUMBAI MARKET)	WEIGHT kg/m	1.570	
PARTY'S DRAWING No.	AS PER SKETCH	SECTION No.	15118	
ALLOY & TEMPER	HE9 WP	DRAWING No.		
DESCRIPTION	MISC TUBE	15118		