

S208

2775

15119

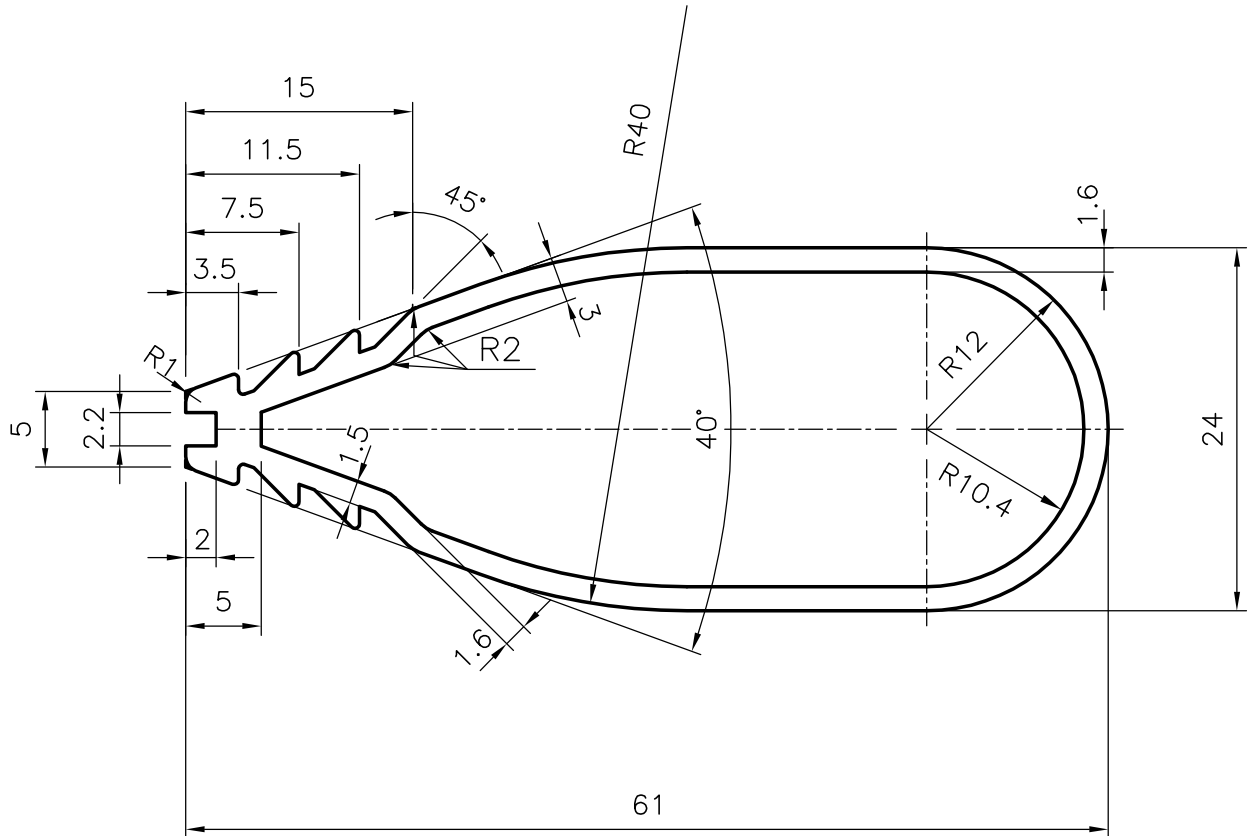
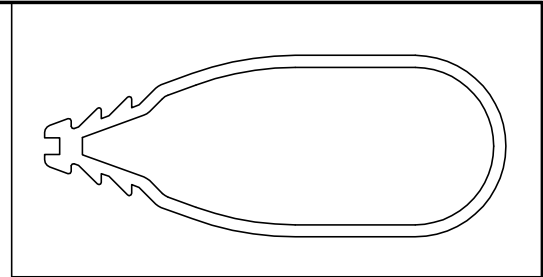

SYMBOL OF QUALITY  
AN ISO 9001 COMPANY

**JINDAL ALUMINIUM LTD.**  
BANGALORE-560073 (INDIA)

	NAME	DATE
DRAWN	J.P.KAUSHIK	03-11-2005
CHECKED		
APPROVED		
SCALE		2:1
AREA mm <sup>2</sup>		237.677
PERIMETER mm.		159.908
WEIGHT kg/m		0.642
DRAWING No.	SECTION No.	
S208	S208	
2775	2775	
15119	15119	

1. ALL DIMENSIONS ARE IN mm.
2. ROUND OFF ALL SHARP CORNERS WITH 0.40 mm.
3. TOLERANCES WILL BE AS PER IS:6477-1983 UNLESS OTHERWISE SPECIFIED

PARTY'S NAME	ROYAL ENGINEERING.,NEW DELHI
PARTY'S DRAWING No.	-
ALLOY & TEMPER	HE9 WP
DESCRIPTION	PEARS TUBE