

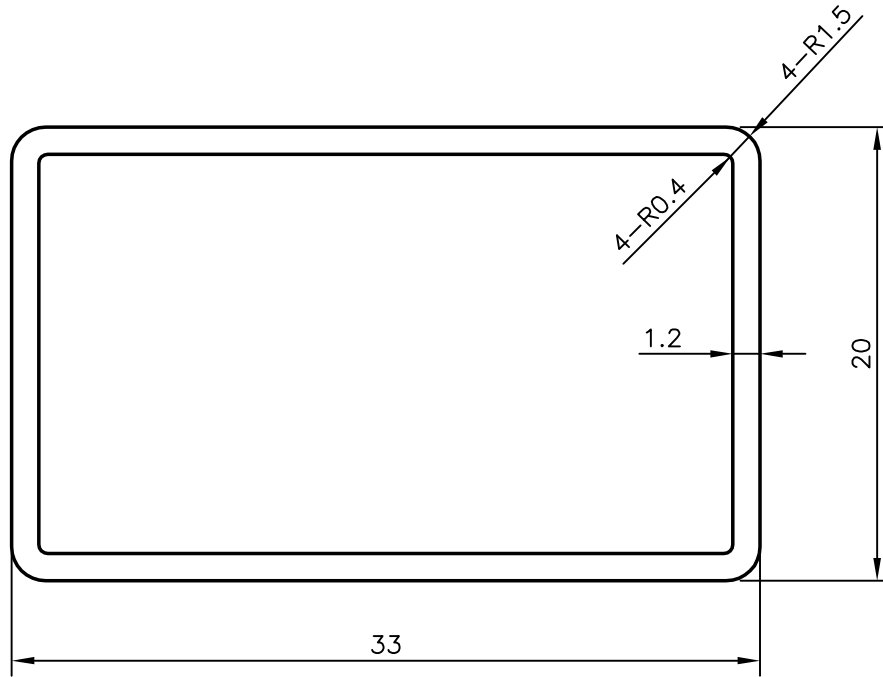

2785

15123

SCALE 1:1



GENERAL WALL THICKNESS = 1.2 mm

| | | | |
|--|--|----------------------|-------------|
|  SYMBOL OF QUALITY AN ISO 9001 COMPANY | JINDAL ALUMINIUM LTD. BANGALORE-560073 (INDIA) | NAME | DATE |
| | | DRAWN PRASANN.H | 22-01-2007 |
| | | CHECKED | |
| | | APPROVED | |
| 1. ALL DIMENSIONS ARE IN mm. 2. ROUND OFF ALL SHARP CORNERS WITH 0.40 mm. 3. TOLERANCES WILL BE AS PER IS:6477-1983 UNLESS OTHERWISE SPECIFIED | | SCALE | 3:1 |
| | | AREA mm ² | 119.646 |
| | | PERIMETER mm. | 103.425 |
| PARTY'S NAME | TRINITY INDUSTRIES., MUMBAI | WEIGHT kg/m | 0.323 |
| PARTY'S DRAWING No. | AS PER SAMPLE | DRAWING No. | SECTION No. |
| ALLOY & TEMPER | HE9 WP | 2785 | 2785 |
| DESCRIPTION | MISCELLANEOUS TUBE | 15123 | 15123 |
| | | - | - |
| | | | |