

P-3561
2796
15130

SOLUTION HEAT TREAT & AGE TO GIVE THE FOLLOWING MINIMUM MECHANICAL PROPERTIES

1. U.T.S. 280N/mm² (MAX 310N/mm²)
2. 0.2% PROFF:-240N/mm² (MAX 265N/mm²)
3. ELONGATION 10%MIN
4. RATIO OF (B)/(A) < 0.90 (IDEAL IS 0.85)
5. REFERENCE WEBSTER B:- 14-15

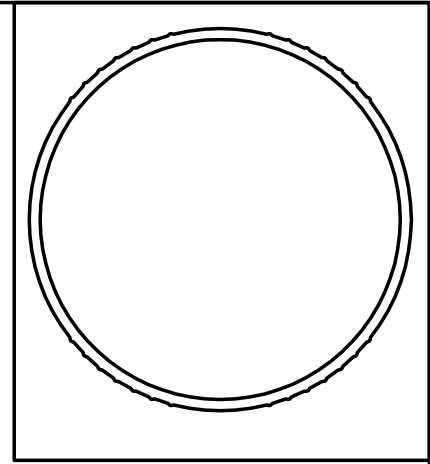

DETAIL "A"
SCALE 20:1

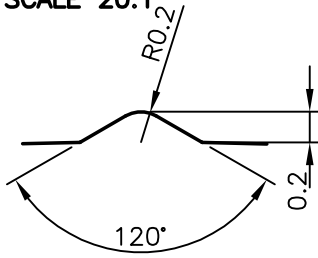

TOTAL 28 RIBS

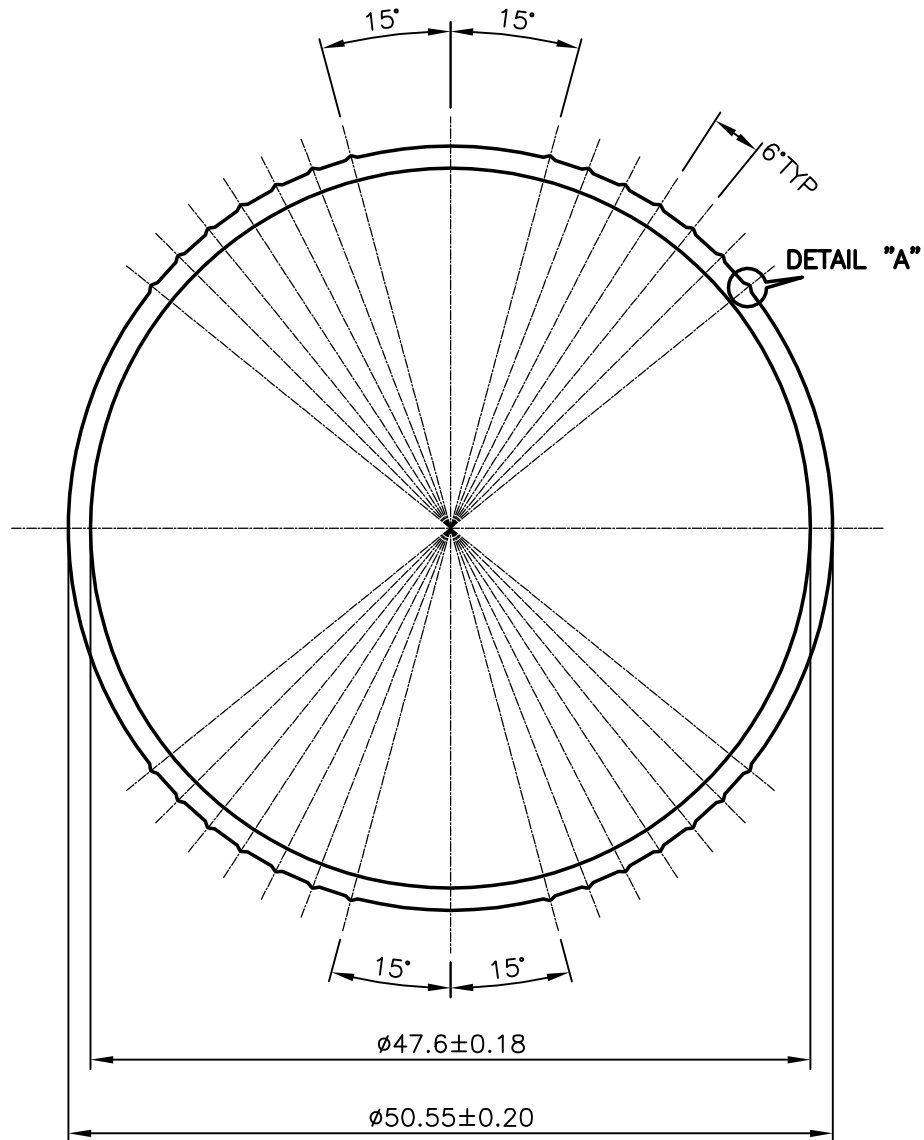

SYMBOL OF QUALITY
AN ISO 9001 COMPANY

JINDAL ALUMINIUM LTD.
BANGALORE-560073 (INDIA)

	NAME	DATE
DRAWN	PRASANN.H	12-12-2006
CHECKED		
APPROVED		
SCALE		2:1
AREA mm ²		229.939
PERIMETER mm.		161.706
WEIGHT kg/m		0.621
DRAWING No.	SECTION No.	
P-3561	-	
2796	2796	
15130	15130	

1. ALL DIMENSIONS ARE IN mm. 2. ROUND OFF ALL SHARP CORNERS WITH 0.40 mm. 3. TOLERANCES WILL BE AS PER B.S 1474-1987 UNLESS OTHERWISE SPECIFIED	
PARTY'S NAME	UP RIGHT IRELAND LTD DUN LAOIRE,.CO. DUBLIN
PARTY'S DRAWING No.	AS PER DRAWING (9880)
ALLOY & TEMPER	6005 T5
DESCRIPTION	FLUTED ROUND TUBE