

P-4360
2825
15147

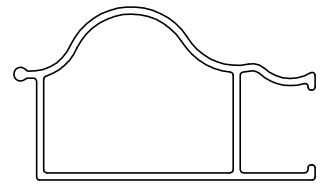

SCALE 1:1

GENERAL WALL THICKNESS = 0.95mm

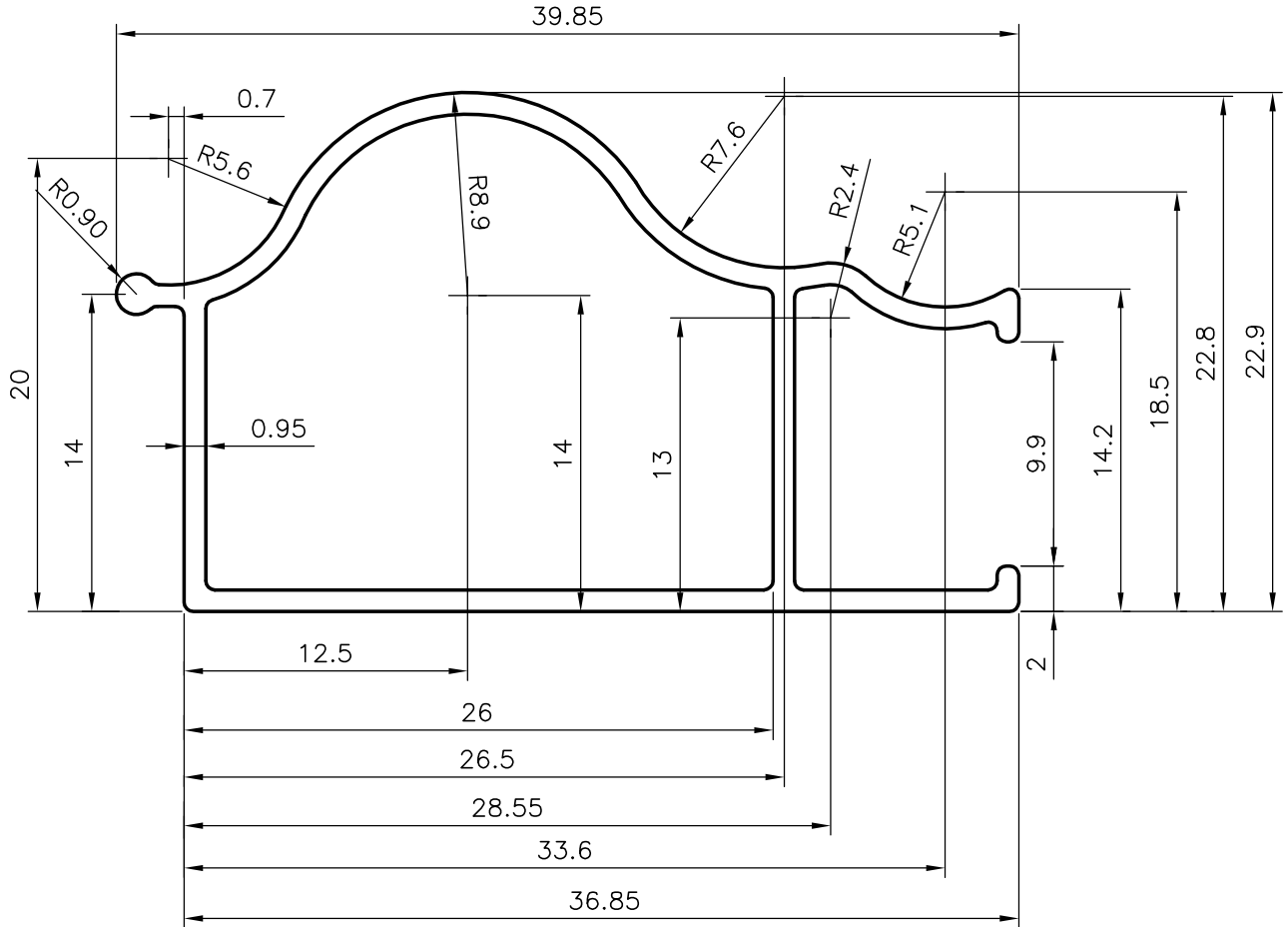

SYMBOL OF QUALITY
AN ISO 9002 COMPANY

JINDAL ALUMINIUM LTD.
BANGALORE-560073 (INDIA)

	NAME	DATE
DRAWN	MALINGAPPA	30-07-2003
CHECKED		
APPROVED		

1. ALL DIMENSIONS ARE IN mm.
2. ROUND OFF ALL SHARP CORNERS WITH 0.40 mm.
3. TOLERANCES WILL BE AS PER IS: 6477-1983 UNLESS OTHERWISE SPECIFIED

SCALE	3:1
AREA mm ²	107.05
PERIMETER mm.	139
WEIGHT kg/m	0.288

PARTY'S NAME	GENERAL CATEGORY, COCHIN MARKET
PARTY'S DRAWING No.	LIGHTER OF SECTION NO. 2802
ALLOY & TEMPER	HE9 WP
DESCRIPTION	MISC. HOLLOW

DRAWING No.	SECTION No.
P-4360	-
2825	2825
15147	15147