

P-3857

X235

15164

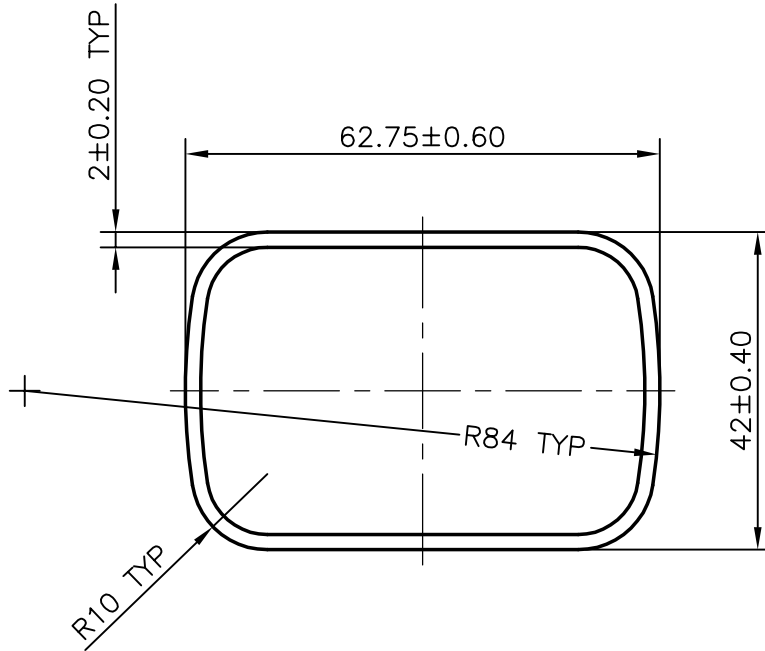

SYMBOL OF QUALITY
AN ISO 9002 COMPANY

JINDAL ALUMINIUM LTD.
BANGALORE-560073 (INDIA)

	NAME	DATE
DRAWN	R.D.Sharma	14-05-02
CHECKED		
APPROVED		

1. ALL DIMENSIONS ARE IN mm.
2. ROUND OFF ALL SHARP CORNERS WITH 0.40 mm.
3. TOLERANCES WILL BE AS PER IS 6477-1983 UNLESS OTHERWISE SPECIFIED

SCALE	1:1
AREA mm ²	365.847
PERIMETER	189.2 mm

PARTY'S NAME	CONFIDENT DENTAL EQUIPMENTS LTD., BANGALORE	WEIGHT kg/m	0.988
PARTY'S DRAWING No.	R & D 847 REV. 00	SECTION No.	15164
ALLOY & TEMPER	HE9 WP	DRAWING No.	15164
DESCRIPTION	HINGE COVER		