

P-5183

15167

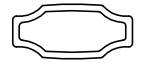

SCALE 1:1

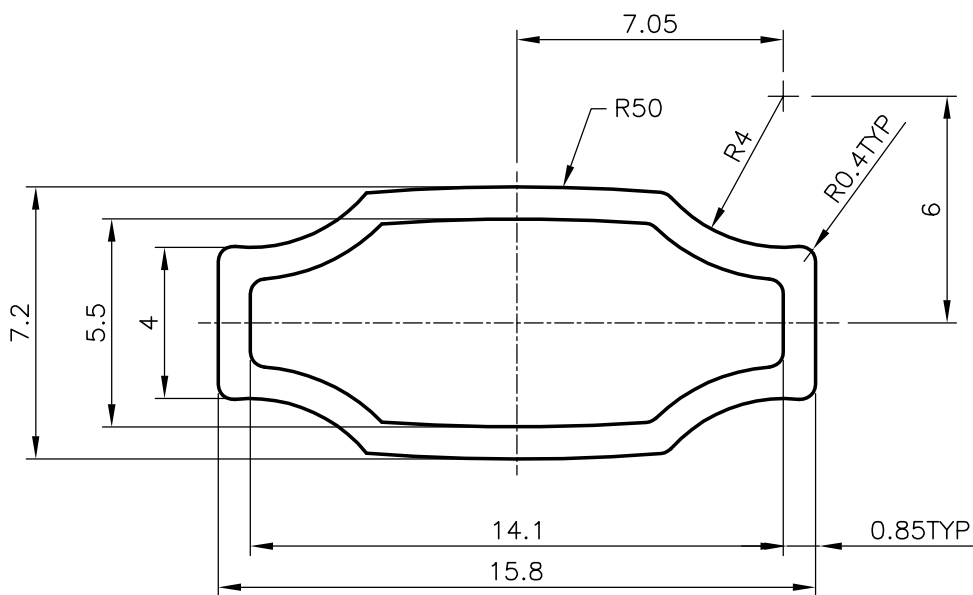

SECTION SHOULD MATCH WITH PARTYS PLASTIC SAMPLE

GENERAL WALL THICKNESS = 0.85mm



SYMBOL OF QUALITY
AN ISO 9001 COMPANY

JINDAL ALUMINIUM LTD.
BANGALORE-560073 (INDIA)

1. ALL DIMENSIONS ARE IN mm.
2. ROUND OFF ALL SHARP CORNERS WITH 0.40 mm.
3. TOLERANCES WILL BE AS PER BS:1474-1987 UNLESS OTHERWISE SPECIFIED

	NAME	DATE
DRAWN	RAGHAVENDRA	13-12-2004
CHECKED		
APPROVED		
SCALE	5:1	
AREA mm ²	32.231	
PERIMETER mm.	40.722	
WEIGHT kg/m	0.087	
DRAWING No.	SECTION No.	
P-5183	-	
15167	15167	

PARTY'S NAME	AL HUTAIB ALUMINIUM & HARDWARE, DUBAI
PARTY'S DRAWING No.	AS PER SAMPLE
ALLOY & TEMPER	6063 T6
DESCRIPTION	MISC. TUBE