

P-7557

15184

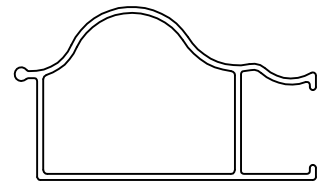

SCALE 1:1

GENERAL WALL THICKNESS = 0.80mm

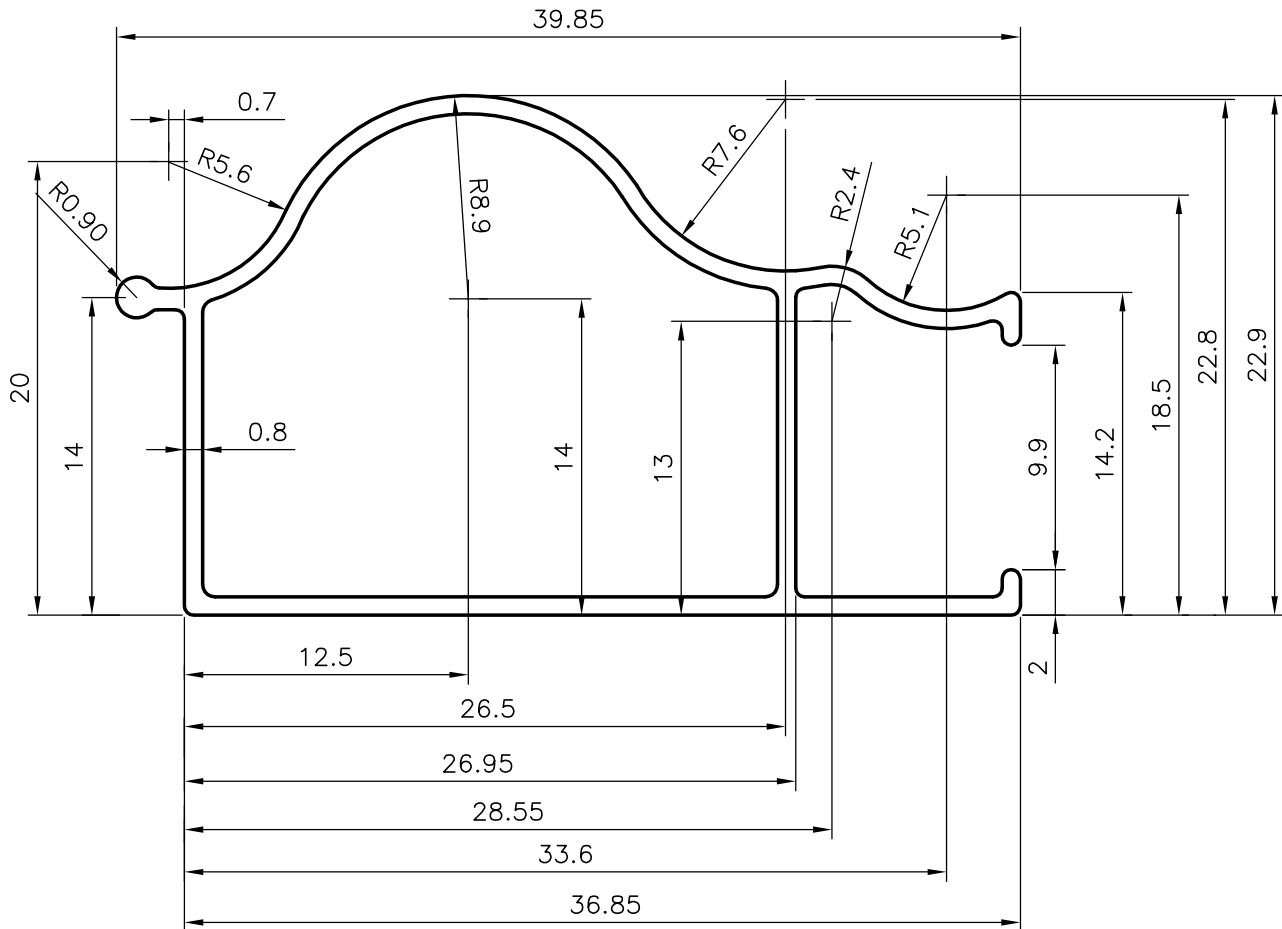

SYMBOL OF QUALITY
AN ISO 9002 COMPANY

JINDAL ALUMINIUM LTD.
BANGALORE-560073 (INDIA)

	NAME	DATE
DRAWN	J.P.KAUSHIK	12-10-2007
CHECKED		
APPROVED		

1. ALL DIMENSIONS ARE IN mm.
2. ROUND OFF ALL SHARP CORNERS WITH 0.40 mm.
3. TOLERANCES WILL BE AS PER IS:6477-1983 UNLESS OTHERWISE SPECIFIED

SCALE	3:1
AREA mm ²	91.58
PERIMETER mm.	139.658
WEIGHT kg/m	0.247

PARTY'S NAME	GENERAL CATEGORY, COCHIN MARKET
--------------	---------------------------------

PARTY'S DRAWING No.	LIGHTER OF SECTION NO. 15147
---------------------	------------------------------

ALLOY & TEMPER	HE9 WP
----------------	--------

DESCRIPTION	MISC. HOLLOW
-------------	--------------

DRAWING No.	SECTION No.
P-7557	-
15184	15184